

Data Sheet TM3-Primus

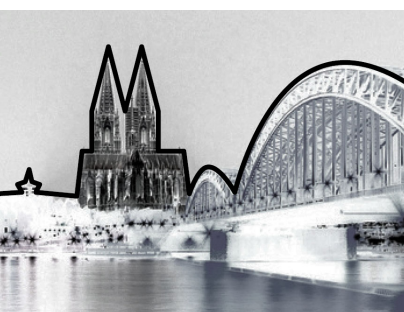

TM3-Primus



Optimized touch screen layout • analog, digital, USB audio inputs • digital output • Smart software • Loudness: EBU, ITU, ATSC, ARIB, OP-59, AGCOM, CALM Act • LRA • PPM/True Peak • Chart • RTA • Monitoring • Moving Coil • Correlator

RTW's TM3-Primus is a highly compact and innovative, easy-to-use product, giving music, voice, and multimedia producers everything they need for loudness and audio metering, including frequently used standard instruments and parameters in a high quality unit to meet the demands of a wide variety of applications. Beside the use as a standalone desktop unit including analog and digital audio interfaces, as well as USB audio, TM3-Primus will also provide an innovative USB hybrid mode. Metering will be performed right from the DAW via

an RTW PlugIn and the TM3-Primus will process and visualize the information without the need for additional wiring or extensive signal routing. The graphical user interface used in TM3-Primus units is controlled simply by using your finger. Instruments can be selected and will be combined for an optimized reading. All commonly used parameters are set, just a few need to be adjusted by the user to meet individual requirements.

Start your measurement. TM3-Primus.

Hardware

TM3-Primus

- Compact unit with full feature set for multifunctional audio measurements (analog, digital, USB audio)
- Table-top unit with display and external USB mains adapter
- 4.3" capacitive touch screen (272 x 480 pixel)
- Optimized screen layout with selectable instruments
- Analog 2-channel stereo input via unbal. RCA, adjustable from -22 dBu (61 mV) to +24 dBu (12.28 V)
- Digital 2-channel stereo in- and output via S/PDIF (RCA)
- Micro-USB connector for digital audio inputs (stereo, 5.1) and USB power supply (USB mains adapter or PC)
- Loudness metering acc. to EBU R128, ITU-R BS.1770-3/1771-1, ATSC A/85, ARIB, OP-59, AGCOM, or CALM Act
- Summing loudness bargraph (M, S, I selectable)
- Numerical display (M, S, I, LRA, TPmax values)
- Loudness measurement control via onscreen keys
- Loudness Range (LRA) instrument with MagicLRA mode
- Loudness Chart instrument for displaying and analyzing the course of a loudness measurement over time
- PPM & True Peak measurement with standard scales
- Moving Coil instruments (PPM, VU, BBC mode)
- Real Time Analyzer (RTA) displaying the spectral distribution of an audio signal
- Audio Vectorscope (Lissajous display)
- Correlator instrument displaying the phase relationship between the two channels of a stereo signal
- Monitoring controller with onscreen level fader (downmix to S/PDIF out connector)



Software

Smart Software Package

With the integrated Smart software package, TM3-Primus is fully equipped. It provides a wide range of RTW's approved loudness and audio metering tools to meet the demands of a wide variety of applications. Beside the signal processing and the control functions this software includes the following instruments:

TP/PPM Bargraph

PPM instrument displaying Peakmeter or TruePeak Meter bargraphs with analog or digital scales and numerical display.

MC - Moving Coil

Moving Coil instrument for the display of needle instruments for 2-channel Stereo with PPM display, VU display, and combined PPM and Loudness display (BBC mode).

Loudness Bar

Loudness Sum instrument for displaying the summed loudness values M, S, or I of a loudness measurement acc. to EBU R128, ITU BS.1770-3/1771-1, ARIB, ATSC A/85, OP-59, AGCOM, CALM Act on a bargraph display.

Numeric Instrument

Loudness Num instrument for the numerical display of relevant values of a Loudness measurement: M, S, I, LRA, TPmax.

Magic LRA

Loudness Range instrument in MagicLRA mode for a graphical representation of loudness variances.

Chart

Loudness Chart instrument for displaying and analyzing the course over time of a loudness measurement directly on the display.

VSC - Vectorscope

2-ch. Audio Vectorscope for displaying the phase relationship between the channels of a channel pair (Lissajous display).

RTA

Real Time Spectrum Analyzer instrument for displaying the spectral content of the input channels using 31 filter bands. Highpass filter for High Band (>20 kHz).

Monitoring

The Monitoring instrument provides a monitoring control function which enables monitoring of displayed audio signals and downmix of USB Surround to S/PDIF Out.

Correlator

Stereo Correlator instrument for displaying the phase relationship between the two channels of a stereo signal and thus its mono compatibility.

Keyboard

Selectable on-screen keys with defined functions for control of loudness measurement in multiple instruments.

Dimensions

Table-top Unit TM3-Primus

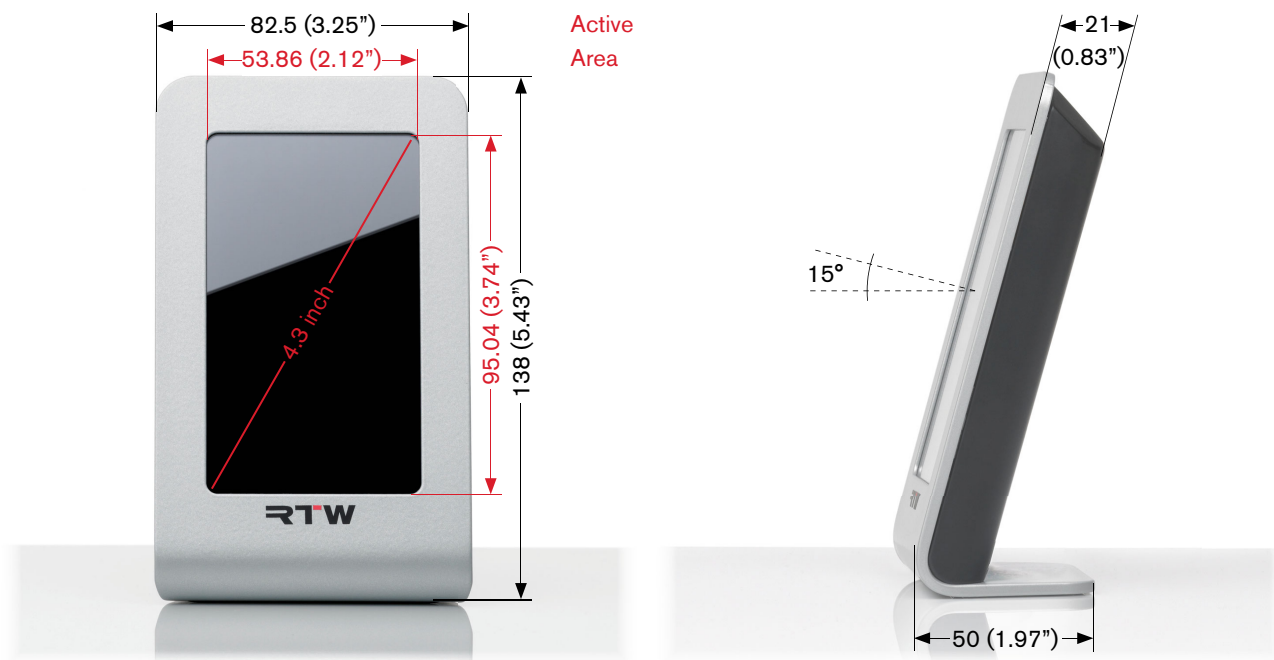

1 | Front view

2 | Side view

Connection

⚠ ATTENTION! - TM3-Primus can be operated either via connection directly from a computer or via mains adapter. For this, TM3-Primus requires an appropriate USB mains adapter and USB connection cable. RTW recommends the use of the approved USB cable and the approved wide voltage USB power supply included in the TM3-Primus package.

Potentiometers for adjustment of the analog input sensitivity for 0 dB reading (61 mV to 12.28 V)



NOTE – Do not disadjust, if not absolutely necessary.

The unit has been calibrated at RTW and offers software calibration for analog 0 dB adjustment.

Please read chapter “Calibration” in the manual before performing adjustment changes!

Analog In R (RCA, unbal.)



Analog In L (RCA, unbal.)



Shield/Chassis (Pin Assignment RCA connectors)

Signal



USB 2.0 Micro-B for:

- Audio input
- Power supply (if connected to a computer, a special Primus USB driver is required, see Specifications)

or:

- Power supply only (if USB mains adapter is used)



Signal lines with RCA connector shall have a ferrite core at the end being connected to TM3-Primus.

S/PDIF Out (RCA, unbal.)



S/PDIF In (RCA, unbal.)



The S/PDIF input is permanently terminated with 75 Ω

It is recommended to use the USB connection cable and USB mains adapter included in the package!

Specifications

System

General

Power requirements:	+5 V DC via USB Micro B connector
Current drain:	400 mA nominal, power-up current is much higher
Display:	Capacitive 4.3" touch screen (272 x 480 pixel)
Connectors:	1 x USB Micro-B; USB 2.0 Full Speed connector for data exchange between computer applications and TM3-Primus, and for power supply via computer or external mains adapter
	2 x RCA-F, analog in (unbalanced, adjustable)
	1 x RCA-F, S/PDIF in (unbalanced)
	1 x RCA-F, S/PDIF out (unbalanced)
Dimensions (W x H x D):	82.5 x 138 x 50 mm
Weight:	approx. 320 g w/o mains adapter
Operating temperature:	+5° to +40° C

Functions

- Operation with one finger (touch sensitive display)
- Optimized screen layout with selectable instruments
- Multiformat PPM/TruePeak for 2-ch. Stereo (analog, digital, PC audio via USB) and 5.1 Surround signals (PC audio via USB)
- Loudness acc. to ITU-R BS.1770-3/1771-1, EBU R128, ATSC A/85, ARIB, OP-59, AGCOM, CALM Act
- Loudness Chart instrument
- Loudness Range instrument (Magic LRA)
- Moving Coil (BR, VU, BBC mode)
- Stereo Correlator
- 1/3-octave spectrum analyzer (RTA)
- 2-channel Audio Vectorscope
- Monitoring (with onscreen level fader)
- Numerical displays

Analog Inputs

Inputs:	2 analog inputs, 2 x RCA-F connectors
Input sensitivity:	-22 dBu (61 mV) to +24 dBu (12.28 V), adjustable via potentiometer (see note below!)
Input calibration RTW:	<ul style="list-style-type: none">• DIN5: 0 dB reading at +6 dBu (1.55 V)• BR IIa: "6" reading at +8 dBu (1.946 V) (UK)• VU: 0 dB reading at +4 dBu (1.228 V) (US)
Reference Levels:	<ul style="list-style-type: none">• for analog scales: additionally adjustable in software in steps of 0.1 dB• for digital scales: relation of dBu to 0 dBFS, adjustable in software in steps of 0.1 dB Example: +6 dBu reads -9 dBFS on TP60 scale with +15 dBu/0 dBFS reference setting
Impedance:	> 10 kΩ



NOTE – Please read the manual before adjustment changes are performed. The unit has been calibrated at RTW. All above mentioned analog references will change, when modifying the input sensitivity.

Digital Inputs/Outputs

	1 digital S/PDIF input, RCA-F, unbalanced, permanently terminated with 75 Ω
	1 digital S/PDIF output, RCA-F
Sampling rates:	28 to 104 kHz, synchronisation to digital input signal

USB Audio Input (requires USB driver to be installed on PC, see Accessory)

Inputs:	Readout and processing of first two USB audio data streams
Modes:	2-ch. Stereo, 5.1 Surround
Sampling rates:	28 to 104 kHz, synchronisation to input signal, internal A/D sample rate @ 48 kHz w/o external digital signal present
Output:	via S/PDIF output connector <ul style="list-style-type: none">• decoded, unchanged USB audio input signal• decoded with or w/o onscreen level fader controlled USB audio input signal, if Monitoring function is activated

TP/PPM Bargraph

Description:	PPM instrument displaying Peakmeter or TruePeak Meter bargraphs with analog or digital scales and numerical display.
--------------	--

PPM instrument

Input sources:	analog, digital, USB audio signals
Peakmeter:	<ul style="list-style-type: none">• analog, digital: 2-ch. Stereo• USB: 2-ch. Stereo, 5.1 Surround
Display:	<ul style="list-style-type: none">• Bargraph with fixed colors:<ul style="list-style-type: none">- yellow: normal- red: headroom• Numerical value on top of the bargraph

Analog Peakmeter

Analog scales:	<ul style="list-style-type: none">• DIN5: +5 .. -50 dB• TP60: +3 .. -60 dB• Nordic: +12 .. -42 dB• BR IIa: 7 .. 1 (British)• SMPTE24: +24 .. -30• NHK
Headroom:	beginning (turning red) at: <ul style="list-style-type: none">• 0 dB on DIN5 scale• -9 dBTP on TP60 scale• +6 dB on Nordic scale• "6" on BR IIa scale• +6 dB on SMPTE24 scale• 0 dB on NHK scale
Integration time:	acc. to standard: Sample (TP60), 20 ms (BR IIa), 10 ms (all others)

Digital Peak-/TruePeakmeter

Word width:	24 bit
Digital scales:	<ul style="list-style-type: none">• TP60: +3 .. -60 dB• Dig60: 0 .. -60 dB• Nordic: +12 .. -42 dB• BR IIa: 7 .. 1 (British)• VU
Headroom:	-9 dBFS, beginning (turning red) at: <ul style="list-style-type: none">• -9 dBTP on TP60 scale• -9 dBFS on Dig60 scale• +6 dB on Nordic scale• "6" on BR IIa scale
Integration time (Attack):	acc. to standard: Sample (Dig60), 4x over sample (TP60), 10 ms (Nordic), 20 ms (BR IIa)



Specifications (continued)

MC - Moving Coil

Description: Moving Coil instrument for the display of needle instruments for 2-channel Stereo with different modes and scales.

Moving Coil Instrument

Modes: PPM (BR IIa), VU, PPM (BR IIa) + Loudness (L/R + I)

PPM Mode

- Ch. arrangement: Stereo horizontal, Stereo vertical
- Scale: BR IIa: 7..1
- Integration time: 20 ms

VU Mode

- Ch. arrangement: Stereo horizontal, Stereo vertical
- Scale analog: VU (-20 to +3 dB)
- Scale digital: VU Digital (-20 to +3 dB)
- Lead: 0 dB, adjustable from 0 to 10 dB in steps of 1 dB

PPM + Loudness Mode

- Ch. arrangement: Dual-PPM with additional Loudness display (BBC) for I in one instrument
- Scales:
 - PPM: see above
 - Loudness: +9 to -9 LU fixed (mid of scale corresponds to Target Level)

Loudness Bar/Numeric instrument

Description: Loudness Sum and Loudness Num instruments for displaying the summed loudness values M, S, or I of a loudness measurement acc. to EBU R128, ITU BS.1770-3/1771-1, ARIB, ATSC A/85, OP-59, AGCOM, CALM Act on a bargraph resp. on a numerical display.

Common Loudness Parameters

Loudness Sum display: One Loudness bargraph selectable:

- M bargraph (Momentary - summation of momentary loudness values of all channels for a short span of time)
- S bargraph (Short - loudness summation value of a dynamic time frame)
- I-Bargraph (Integrated - long term loudness value infinite or manual control)
- Onscreen keys for measurement operation: Start, Stop, Reset Loudness

Loudness Num display: M, S, I, TPmax, LRA values, selectable

Weighting filter: K filter acc. to ITU BS.1770

Level settings for summation

- (channel weighting):
- 0.0 dB (L, R, C)
 - +1.5 dB (LS, RS)
 - Off (LFE)

TruePeak Over Threshold: -1 dBTP; adjustable from 0 to -4 dBTP in steps of 1 dBTP

EBU R128 Loudness Mode

Target Level: -23 LUFS; adjustable from -10 to -30 LUFS in steps of 0.5 LUFS

Scale: EBU+9: +9 .. -18 LU (Loudness Units)

M Integration time: 400 ms (SQR)

S Integration Time: 3 s

I Silence Gate: -70.0 LUFS

I Relative Gate: -10.0 LU

I Tolerance Range: ±1 LU

Over Sensitivity: -1 dBFS

Over hold time: 1 s

ITU BS.1771 Loudness Mode

Target Level: -24 LKFS; adjustable from -10 to -30 LKFS in steps of 0.5 LKFS

Scale: ITU+9: +9 .. -18 LU (Loudness Units)

M Integration time: 400 ms (SQR)

S Integration Time: 3 s

I Silence Gate: -70.0 LKFS

I Relative Gate: -10.0 LU

I Tolerance Range: ±2 LU

Over Sensitivity: -2 dBFS

Over hold time: 1 s

ATSC A/85 Loudness Mode

Target Level: -24 LKFS; adjustable from -10 to -30 LKFS in steps of 0.5 LKFS

Scale: ATSC0: 0 .. -60 LKFS

M Integration time: 400 ms (SQR)

S Integration Time: 3 s

I Silence Gate: -70.0 LKFS

I Relative Gate: -10.0 LU

I Tolerance Range: ±2 LU

Over Sensitivity: -2 dBFS

Over hold time: 1 s

ARIB Loudness Mode

Target Level: -24 LKFS; adjustable from -10 to -30 LKFS in steps of 0.5 LKFS

Scale: ATSC0: 0 .. -60 LKFS

M Integration time: 400 ms (SQR)

S Integration Time: 3 s

I Silence Gate: -70.0 LKFS

I Relative Gate: -10.0 LU

I Tolerance Range: ±0 LU

Over Sensitivity: -1 dBFS

Over hold time: 1 s

OP-59 Loudness Mode

Target Level: -24 LKFS; adjustable from -10 to -30 LKFS in steps of 0.5 LKFS

Scale: ATSC0: 0 .. -60 LKFS

M Integration time: 400 ms (SQR)

S Integration Time: 3 s

I Silence Gate: -70.0 LKFS

I Relative Gate: -10.0 LU

I Tolerance Range: ±2 LU

Over Sensitivity: -2 dBFS

Over hold time: 1 s

AGCOM Loudness Mode

Target Level: -24 LKFS; adjustable from -10 to -30 LKFS in steps of 0.5 LKFS

Scale: ATSC0: 0 .. -60 LKFS

M Integration time: 400 ms (SQR)

S Integration Time: 3 s

I Silence Gate: -70.0 LKFS

I Relative Gate: -8.0 LU

I Tolerance Range: ±0.5 LU

Over Sensitivity: -2 dBFS

Over hold time: 1 s

CALM Loudness Mode

Target Level: -24 LKFS; adjustable from -10 to -30 LKFS in steps of 0.5 LKFS

Scale: ATSC0: 0 .. -60 LKFS

M Integration time: 400 ms (SQR)

S Integration Time: 3 s

I Silence Gate: -70.0 LKFS

I Relative Gate: -10.0 LU

I Tolerance Range: ±2 LU

Over Sensitivity: -2 dBFS

Over hold time: 1 s



Specifications (continued)

Magic LRA

Description: Loudness Range instrument in MagicLRA mode for a graphical representation of loudness variances.

Loudness Range Instrument (LRA)

Display: Graphical display of the Loudness Range
Mode: MagicLRA: dynamic bargraph spreading around a zero-point, changing its color when passing the preset ranges
Scale range: -10 LU to +10 LU
LRA low range: 5 LU
Comfort zone: 10 LU
LRA high range: outside the comfort zone
Color: green, blended in 3 steps from dark to light acc. to low range, comfort zone, high range

Chart

Description: Loudness Chart instrument for displaying and analyzing the course over time of a loudness measurement directly on the display.

Loudness Chart Instrument

Functions:

- Coordinate system displaying a graph with the course over time of one of the measured values TP, M, S, or I
- Relative Gate view switchable
- Adjustable time ranges
- Vertical Integrated bargraph switchable
- Adjustable tolerance levels

Display:

- Course over time of the selected value with color filling or as line
- Tolerance Marker
- Position of the Relative Gate (doubled horizontal line)
- Vertical I bargraph

Colors:

- Fill: Adoption of the corresponding colors of the Loudness Sum instrument
- Line: cyan (M), light red (S), green (I), yellow (TP)
- Tolerance Marker: coordinate system turns to light grey except the corridor defined by the tolerance settings
- Relative Gate: white

Time range presets: 1 m; 1 m, 5 m, 1 h selectable
Time range select: via preset or onscreen during normal operation
Lower tolerance: -0.0 LU; tolerance below the Target Level, adjustable from 0 to -6 LU in steps of 0.5 LU
Upper tolerance: 0.0 LU; tolerance above the Target Level, adjustable from 0 to 6 LU in steps of 0.5 LU

VSC - Vectorscope

Description: 2-ch. Audio Vectorscope for displaying the phase relationship between the channels of a channel pair (Lissajous display).

Audio Vectorscope Instrument

Display mode: 2-channel
Inputs: L/R
AGC: fast
Grid: L/R

RTA

Description: Real Time Spectrum Analyzer instrument for displaying the spectral content of the input channels using 31 filter bands. Highpass filter for High Band (>20 kHz).

Real Time Spectrum Analyzer (RTA) Instrument

Functions:

- Peak hold on/off
- Set reference
- Selectable resolution

Input sources: Stereo pairs
Frequency range: 20 Hz to 20 kHz, highpass filter for High Band (>20 kHz)
Number of bands: 1/3-octave: 31 bands, filter acc. to IEC 225 class 2
Weighting filter: Linear
Peak hold indicator: 4 s, 2 s, off
Measuring range: 45 dB max.
Resolution: 3, 6, 9 dB
Reference: 0.0 dB; adjustable from 0.0 to 21.0 dB in steps of 1 dB
Integration time (ballistics): Fast

Monitoring

Description: The Monitoring instrument provides a monitoring control function which enables monitoring of displayed audio signals.

Monitoring Instrument

Functions:

- Monitor level control with onscreen level fader
- Mute, Dim
- Internal Downmix for multichannel monitoring, audio output of monitoring signals via S/PDIF out connector.

Output: Digital 2-ch. Stereo (S/PDIF out, unbal., RCA-F)

Correlator

Description: Stereo Correlator instrument for displaying the phase relationship between the two channels of a stereo signal and thus its mono compatibility.

Correlator Instrument

Display: Bargraph, additional spot indicator between PPM bargraphs
Scale range: -1 r to 0 to +1 r
Standard color setting: red: -1 r to -0.1 r
white: 0 r (-0.1 r to +0.1 r)
green: +0.1 r to +1 r
Attack/release time: 1.0 s/2.5 s

Items of Delivery

TM3-Primus:

- Display unit with 4.3" touch screen in a tabletop case for 2-channel analog or digital stereo audio signals, or stereo and 5.1 USB audio
- USB-A to Micro-USB-B connecting cable, 1.5 m length
- USB mains adapter, manual

Order no.: TM3-Primus

Accessory

USB-Driver: USB-Driver-Software to run TM3-Primus in USB audio input mode also on Windows® systems. Installer available for download at Audio Monitors/TM3-Primus section of members area on our website: <https://www.rtw.com/en/service/manuals-software.html>

Block Diagram

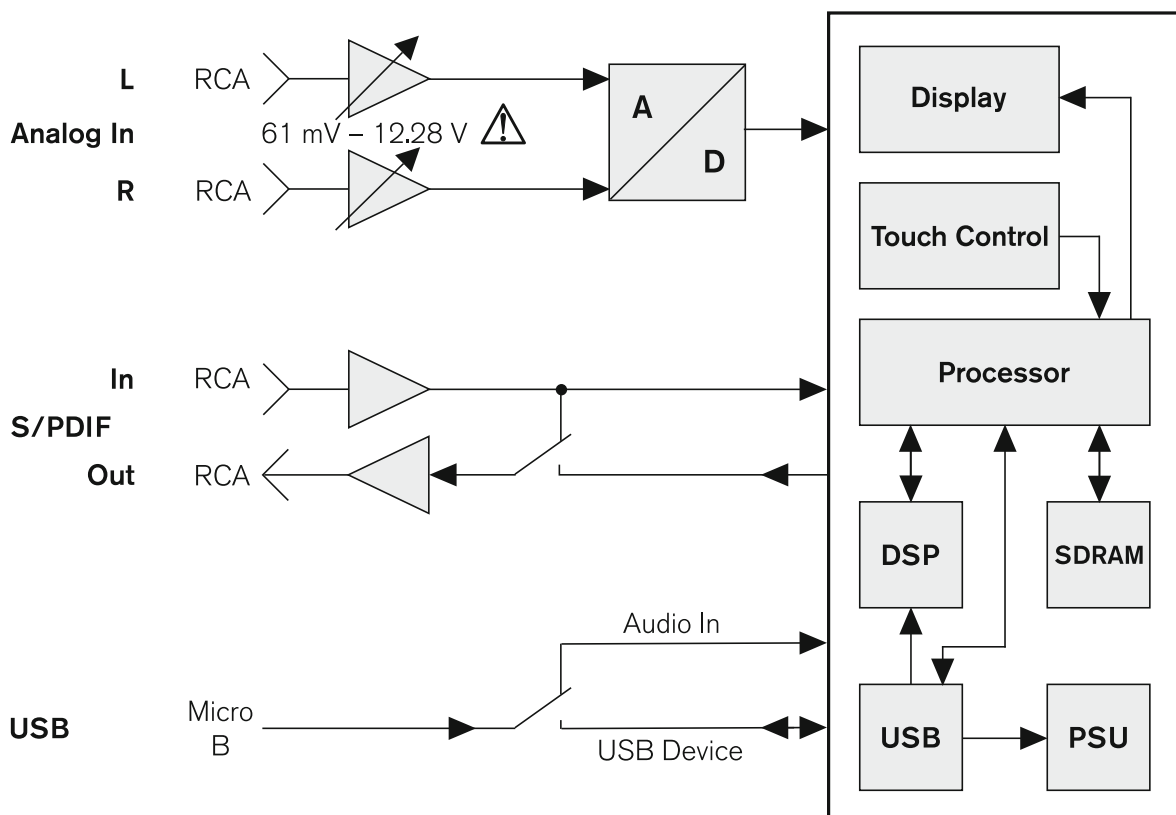

 **Calibrated at RTW. Please refer to manual before readjustment!**

© 09/2014 | Technical changes without prior notice.