

MINIATURE MICROPHONES
FROM DPA MICROPHONES



DPA 
MICROPHONES

To learn more about DPA's miniature microphones and find the model that best meets your requirements, please visit www.dpamicrophones.com.

Contents

DPA 4060, 4061, 4062 & 4063	4
DPA IMK4060 & IMK4061	6
DPA SMK4060 & SMK4061	8
DPA 4071, 4073, EMK & FMK	10
DPA 4080	12
DPA 4065, 4066 & 4067	14
DPA 4088	16
DPA MSS6000	18
DPA BLM4060	20
Adapters	22
Accessories	27
Specifications	32

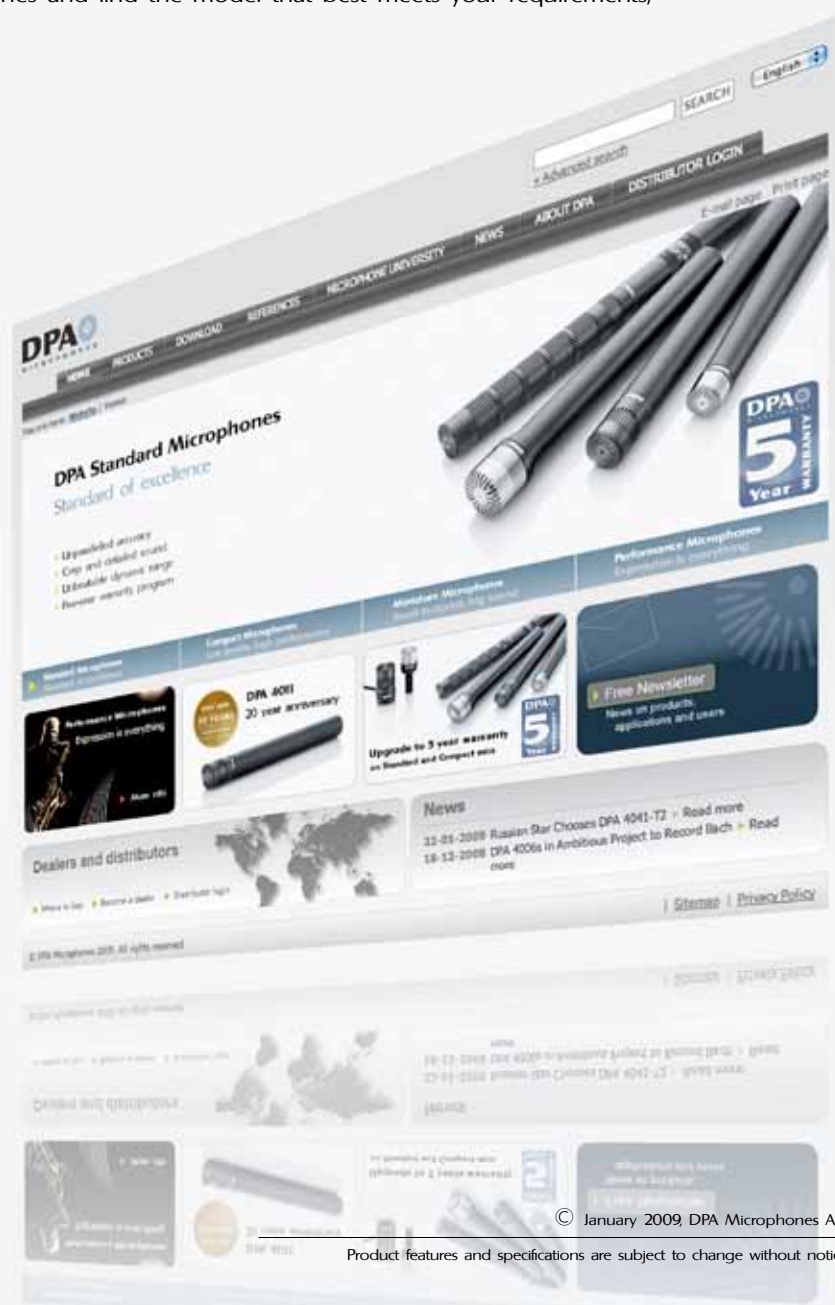

Then and now

Since the launch of its first product in 1992, DPA Microphones has firmly established itself as one of the world's preeminent manufacturers of microphones for studio and location recording, broadcast, theater and live sound. Building upon the respected legacy of Brüel & Kjær, DPA's reputation for capturing an extremely natural and open sound – especially noticeable when recording vocals and traditional acoustic instruments – has provided the brand with unprecedented growth over the past two decades.

Universal approach

The same skillful design and “no compromises” approach to manufacturing that are embodied by DPA Microphones have been extended to our line of miniature condenser microphones, ingenious accessories and tailor-made solutions for a wide variety of demanding applications. Form and function are key aspects of our design philosophy and contribute significantly to the continued success of our products.

Headworn or lavalier

DPA's headworn miniature microphones are the mics of choice in live theater and musical productions, as well as for houses of worship and corporate events. For serious recording and sound reinforcement, DPA meets the challenge with exceptional technical specifications and creative mounting accessories for any musical instrument, while the miniature lavalier microphones designed for concealed use in broadcast and film production demonstrate a previously unheard clarity and speech intelligibility.

Professional microphone solutions for any need



Handcrafted in Denmark

DPA 4060, 4061, 4062 & 4063 Miniature Omnidirectional Microphones

Small footprint, big sound

DPA is without equal when it comes to the 4060 range of miniature omnidirectional condenser microphones. Originally designed for use with wireless systems in theater, television and close-miked instrument applications, the highly unobtrusive capsule is visually smaller than a pencil eraser.

Same yet different

The award-winning DPA 4060 has a very low noise floor, impressive sensitivity and can handle high SPLs. The DPA 4061, 4062 and 4063 are acoustically identical to the 4060 but have been adjusted to handle higher SPL and to match some of the more sensitive transmitters on the market. The 4063 also features a FET preamp designed to be used with RF systems delivering as low as 3 V to the microphone.

Need a boost?

Two different protection grids are supplied and by changing these grids you can acoustically modify the microphones response according to their placement on the body. One gives you a 3 dB of boost in the 8 - 20 kHz range, while the other gives you a 10 dB boost at 12 kHz.

Get connected

The miniatures also have another innovative design feature: the MicroDot connector system. The tiny but rugged connector allows you to securely attach a wide variety of available adapters. This useful feature effectively multiplies your mic inventory since you can use the same microphone element on a variety of transmitters and even with XLR inputs. Choose between our adapter system or a hardwired connector.

Hear everything, see nothing

Because of their small size, these miniature mics exhibit an exceedingly accurate omnidirectional pattern and therefore do not need to be aimed directly at the sound source to achieve quality pickup. Offering great detail and resolution, they have a neutral sonic character and are very natural sounding. On stage, the tiny mics are literally undetectable, being both extremely rugged and reliable, even under the most punishing conditions (high heat, humidity, wind, dust, etc.).

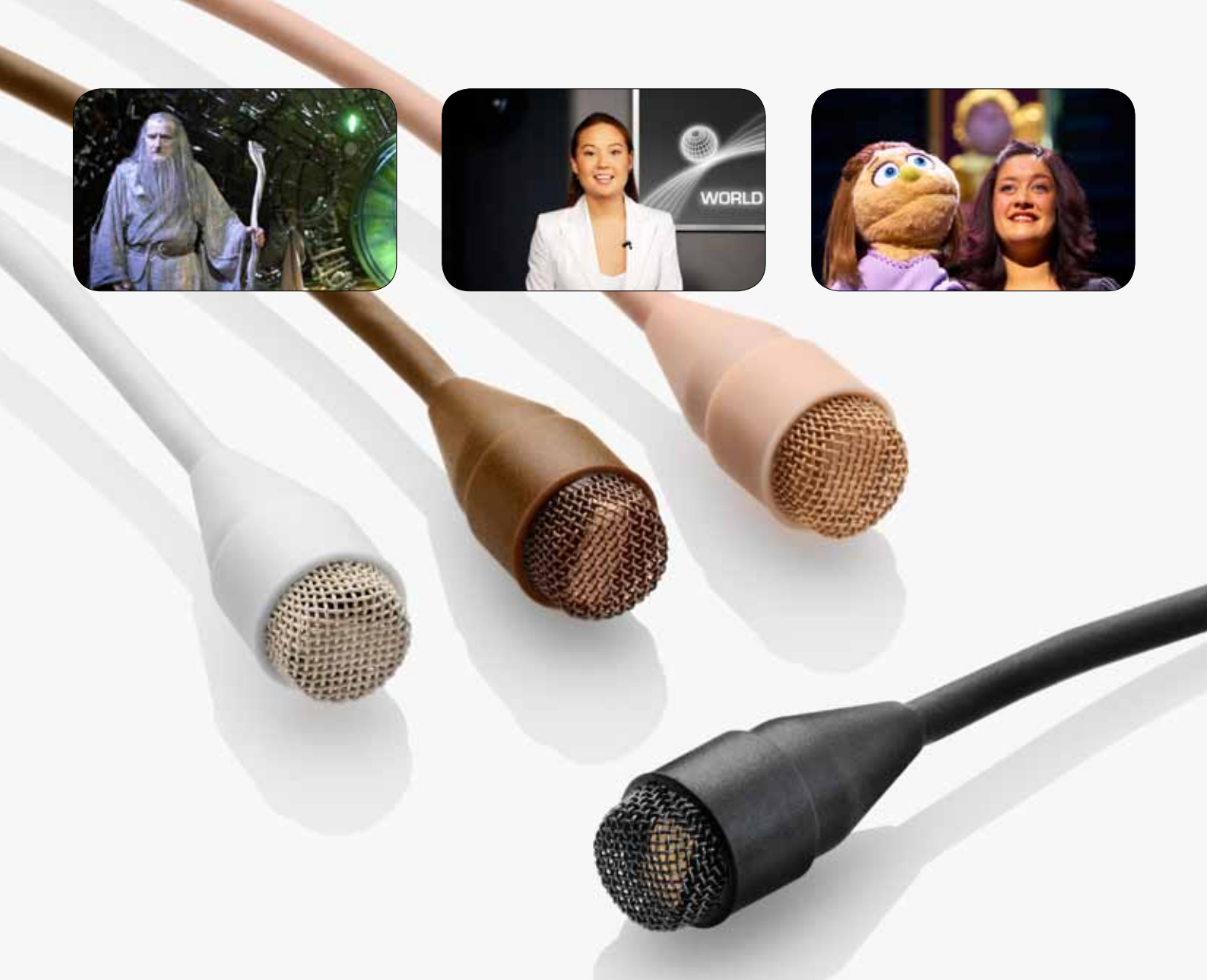

DPA 4060, 4061, 4062 & 4063 Key Features

- Neutral sound character with great detail
- Low noise and high sensitivity
- Large dynamic range
- Fits numerous transmitters

DPA IMK4060 & IMK4061 Instrument Microphone Kit

In the zone but out of the way

The 4060 and 4061 at the heart of DPA IMK4060 and IMK4061 Instrument Microphone Kits represent the perfect combination of sonic purity and versatility. The tiny size and light weight of these mics make them extremely unobtrusive, ensuring that they'll never get in the way of capturing an outstanding performance.

Handle the pressure

Equipped with a MicroDot to XLR adapter and well chosen accessories designed to aid mounting the microphone on, and even in, a wide range of instruments, these kits offer very clean, detailed and natural sound. Capable of handling a robust 144 dB peak before clipping, the microphones can be used even for snare drums, trumpets, guitar and bass speaker cabinets or other high SPL sources.

IMK4060 includes

1 x 4060-BM	Omnidirectional Mic, Black, High-Sens
1 x DAD6001-BC	MicroDot to 3-pin XLR (P48)
1 x DMM0002-B	Double Pin, Black
1 x DMM0007	Universal Surface Mounts, 5 pcs.
1 x DMM0011-B	Magnet Mount, Black
1 x DUA0560	Windscreens, Black, 5 pcs.
2 x MHS6001	Holder for Strings

IMK4061 includes

1 x 4061-BM	Omnidirectional Mic, Black, Low-Sens
1 x DAD6001-BC	MicroDot to 3-pin XLR (P48)
1 x DMM0002-B	Double Pin, Black
1 x DMM0007	Universal Surface Mounts, 5 pcs.
1 x DMM0011-B	Magnet Mount, Black
1 x DUA0560	Windscreens, Black, 5 pcs.
2 x MHS6001	Holder for Strings

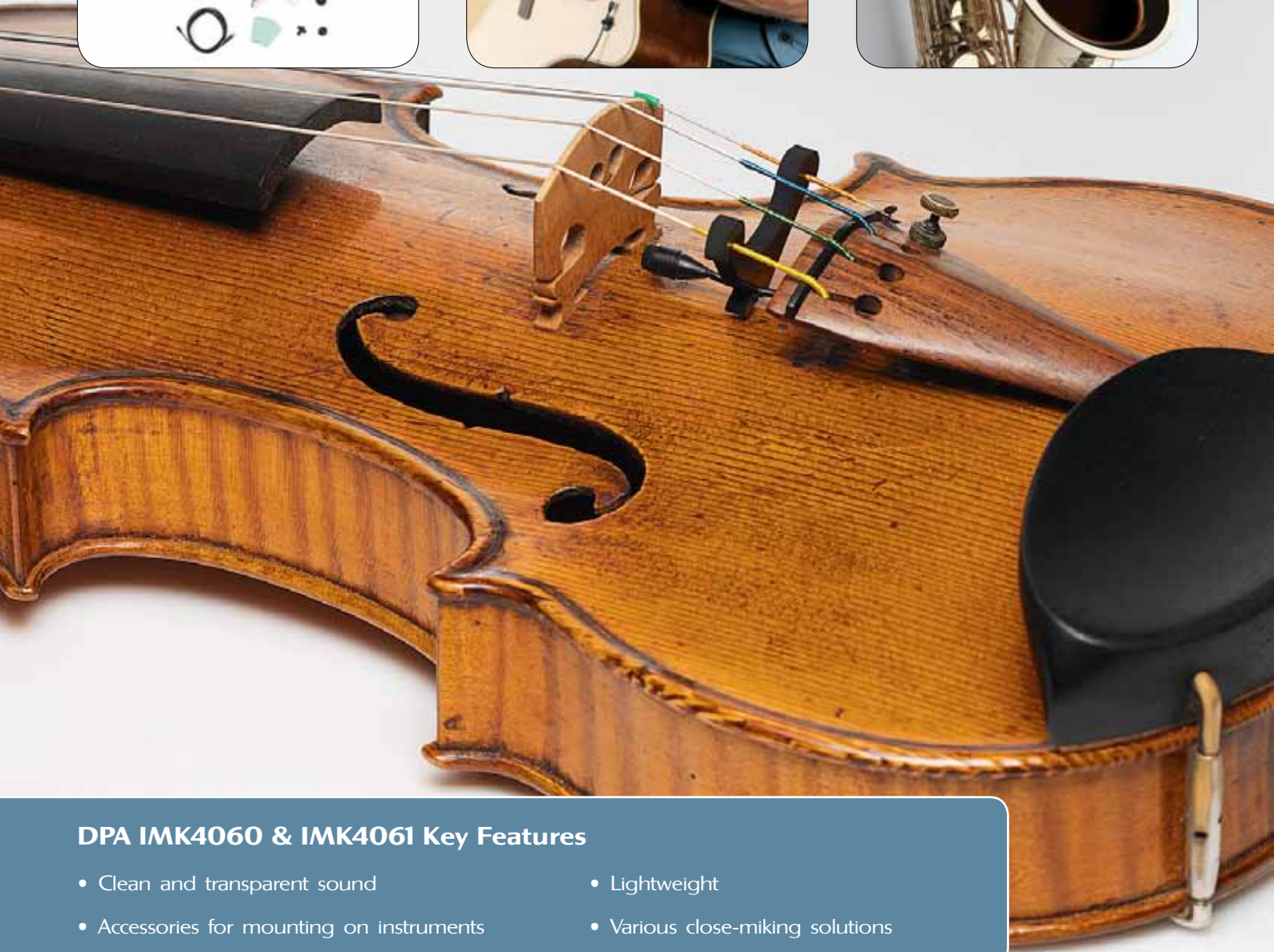

DPA IMK4060 & IMK4061 Key Features

- Clean and transparent sound
- Accessories for mounting on instruments
- Lightweight
- Various close-miking solutions

DPA SMK4060 & SMK4061 Stereo Microphone Kit

Left and right

The SMK4060 and SMK4061 Stereo Microphone Kits are cost-effective and flexible live sound and recording solutions ideal for recording studios and discreet mic setups on stage. The SMK4060 features two DPA 4060 high-sensitivity omnidirectional miniature microphones while the SMK4061 combines two low-sensitivity DPA 4061 mics.

Ready for anything

Offering clean, transparent sound with plenty of headroom, each kit is supplied with two MicroDot to XLR adapters and includes distinctive accessories for mounting the microphones on a wide variety of surfaces, including music stands, instruments, walls, stage floors and piano lids.

SMK4060 includes

2 x 4060-BM	Omnidirectional Mic, Black, High-Sens
2 x BLM6000-B	Boundary Layer Mount, Black
2 x DAD6001-BC	MicroDot to 3-pin XLR (P48)
1 x DMM0007	Universal Surface Mounts
2 x DMM0011-B	Magnet Mount, Black
1 x DUA0560	Windscreens, Black
2 x MHS6001	Microphone Holder for Strings

SMK4061 includes

2 x 4061-BM	Omnidirectional Mic, Black, Low-Sens
2 x BLM6000-B	Boundary Layer Mount, Black
2 x DAD6001-BC	MicroDot to 3-pin XLR (P48)
1 x DMM0007	Universal Surface Mounts
2 x DMM0011-B	Magnet Mount, Black
1 x DUA0560	Windscreens, Black
2 x MHS6001	Microphone Holder for Strings



DPA SMK4060 & SMK4061 Key Features

- Natural and dynamic reproduction
- Boundary layer mounting possible
- Discreet solution
- Close-miking stereo pair solutions

DPA 4071, 4073, EMK & FMK Miniature Omnidirectional Microphone with Presence Boost

Television and movie stars

The DPA 4071 is an omnidirectional miniature condenser microphone designed for television broadcast and film applications. Its frequency response is customized for maximum vocal clarity in body-worn and concealed applications, with a low-end roll off and presence boost, making this an ideal sounding microphone to use in the field or on the set. The DPA 4073 is acoustically identical to the 4071, but the FET preamp is designed to match transmitters delivering as low as 3 V to the microphone.

Boost and cut

To achieve optimal speech intelligibility, the inconspicuous 4071 features a specially designed fixed microphone grid that provides a soft presence boost of 5 dB at 4 - 6 kHz, for maximum clarity and definition. Furthermore, the low-cut filter is done acoustically at the capsule allowing for greater headroom in the signal path.

DPA 4071 Kits

When it is imperative that the microphone be invisible for film or TV production, the FMK4071 Film Microphone Kit pairs the 4071 with a miniature concealer, tie pods, various pre-cut tape pieces, as well as a windjammer and miniature mesh filter to avoid pops and wind noise.

In the field, on the air

When the microphone may be visible, such as in ENG and EFP applications, the EMK4071 ENG/EFP Microphone Kit comes supplied with a variety of pins, clips and holders, a mix of multi-colored windscreens, and both a windjammer and miniature mesh filter. For even greater clarity of speech, the kit includes an XLR adapter that provides 3 dB of attenuation at 800 Hz as a final tonal adjustment for going directly on-air or to track without editing.

EMK4071 includes

4071-BM	Omnidirectional Mic with Presence Boost, Black
DAD6024	XLR Adapter with Mid Range Attenuation
DMM0002-B	Double Pin, Black
DMM0005	Holder, Single Pin
DMM0008-B	Clip, Double Lock, Black
DUA0570	Windscreens, Color Mix, 8 pcs
DUA0571	Windjammer, Grey Fur
DUA0572	Mesh

This kit is also available without microphone and adapter as DAK4071-E.

FMK4071 includes

4071-BM	Omnidirectional Mic with Presence Boost, Black
ADH0001	Double-sided tape for Tie Pod, 10 pcs.
ADH0003	Mic Tape, 10 pcs.
ADH0004	Double-sided Mic Tape
ADH0002	Double-sided tape for Concealer, 10 pcs.
DMM0009	Concealer
DMM0010	Tie Pod, 3 pcs.
DUA0571	Windjammer, Grey Fur
DUA0572	Mesh

This kit is also available without microphone as DAK4071-F.



DPA 4071, 4073, FMK4071 & EMK4071 Key Features

- Customized for chest mounting
- Optimal speech intelligibility
- Mounting accessories for concealing
- Straight to broadcast without editing

DPA 4080 Miniature Cardioid Microphone, Lavalier

Clarity unquestioned, discretion assured

The DPA 4080 Miniature Cardioid Microphone, Lavalier combines optimum speech intelligibility with a discreet, compact design to create a high-performance lavalier microphone for broadcast, conference and other live performance applications.

Good things come in small packages

Small and discreet, the 4080 sets a new standard for great sound in a sleek design. Sound professionals will appreciate the light weight and the excellent speech reproduction. Because of the flexible and practical mounting solution, the DPA lavalier microphone can easily be turned in all directions and can be worn on either the right or left lapel.

Highly compatible

A broad range of optional connection adapters is offered for most professional transmitters so that news anchors and conference speakers are free to use their hands and move around without compromising voice quality.

Built to last

The 4080 is supplied with a pre-mounted pop-filter in a durable holder with an integrated shock mount, attached to the DPA clip. All parts of the microphones are manufactured from highly resistant materials and are designed to perform under stress.

Natural performer

The frequency response of the DPA 4080 lavalier is tailored to body-worn applications. Acoustically pre-equalized with a 4 dB presence boost, the 4080 captures the human voice with an unusually high degree of definition, even when the acoustic environment is less than favorable.



DPA 4080 Key Features

- Excellent speech reproduction
- Rejects background noise
- Wear on either right or left lapel
- Fits numerous transmitters

DPA 4065, 4066 & 4067 Omnidirectional Headbands

Double header

The DPA 4065 and 4066 omnidirectional headband mics use the same tiny microphone element and are acoustically and electrically identical to the popular 4061. Despite their diminutive size, both headsets can handle up to 144 dB SPL before clipping.

For one...

Designed for everyday use on the same performer, the 4065 headband mic offers maximum performance for stage, broadcast and home studio applications. The headband is exceptionally lightweight and easily formed to the individual shape of each performer's head, providing a firm yet comfortable fit.

...and for all

With its highly robust construction and option for left or right mounting, the 4066 headband mic is particularly well-suited for environments where there is a different user every day. Especially popular with theaters on Broadway and West End, the system is designed for actors, public speakers, broadcast hosts, musicians and singers. Quickly and easily adjusted, the 4066 is an extremely lightweight and versatile tool.

Low voltage

The DPA 4067 is a low DC and extra low sensitivity version of the 4066, which it is acoustically identical to. Also, the built-in FET preamp is designed for working with RF systems that supply as low as 3 V to the microphone. The 4067 furthermore features an acoustical 6 dB/octave low cut (-3 dB at 40 Hz).

Moisture-proof design

DPA's headband mics are all equipped with a double vent protection system, sweat stopper on the tube and water resistant materials inside the capsule, which allow the microphones to operate reliably even in high-humidity applications.

Well connected

All miniature mic cables are terminated with DPA's innovative MicroDot connector, which permits connection with most of the professional transmitters on the market via one of DPA's numerous adapter accessories. Special adapters have even been developed for compatibility with systems supplying less than 5 V to the mic.

Blending in

All three of DPA's headband microphones are available in a choice of colors and sizes, and supplied with multiple windscreens. The 4066 and 4067 are each also accompanied by both one high boost and one soft boost miniature grid.



DPA 4065, 4066 & 4067 Key Features

- The standard headband mic for theaters and broadcasters
- Resistant to sweat and wear
- Easy to adjust
- Natural sound capture

DPA 4088 Cardioid Headband

Superior gain-before-feedback

The DPA 4088 is a miniature cardioid headband designed for acoustically demanding live performance environments. In high SPL events and when feedback is a concern, the 4088 will tackle these challenges with ease.

Perfectly natural

With its extremely open, clear and natural sound, the 4088 rarely requires any equalization. You hear the voice – pure and simple – not the microphone. Sound quality, visual elegance and true versatility work together to transform every show into the performance of a lifetime.

Bass in its place

The side address capsule is hidden in a small and ultra-lightweight housing. The bass response is designed for optimal linearity at 2 - 3 centimeters (about 1 inch) from the sound source. This means that the bass roll-off will be more prominent at a greater distance – an important factor when it comes to rejection of background noise and the fight to avoid feedback.

Rugged build

The mechanical design is based on the proven construction quality of the 4066 headband microphone. The headband mount is exactly the same; however, the boom is 3 centimeters longer to match the need for placement at the corner of the mouth.

It is available in three colors: beige, brown, and black, and in three different sizes to fit any head size.



DPA 4088 Key Features

- Fits any head size and shape
- Optimizes gain before feedback
- Integrated pop protection
- High sound pressure level handling

DPA MSS6000 Microphone Summation System

Assembling the ensemble

The MSS6000 is a professional Microphone Summation System designed to reduce cable clutter on stage and simplify channel control off stage when using several DPA miniature microphones in conjunction with group performances. The ultimate ensemble amplification system for orchestras, bands and choirs, the MSS6000 frees up many useful and costly channels without compromising the desired sound quality.

Ten to two

The system consists of five stereo satellite boxes (SSB6000), offering individual level and pan adjustment for every performer, and a master sum box (MSB6000) containing two high-performance, transformer-coupled mic preamplifiers. Thus, a single system in array provides control of up to 10 performers and will reduce an entire section of 10 down to two channels on a stage box and mixing console. Individual boxes are available to expand the system in a modular chain.

Portable durability

All of the components used in the MSS6000 system have been carefully selected to provide superior sound quality as well as electrical and mechanical durability in a compact, portable system. The robust electronics design and shielding ensure a high degree of electro-magnetic protection. No separate power supply unit is required, as two channels of 48 V phantom power drive the entire system from the mixing console.

Sum it all up

A complete set of ten DPA 4061 miniature microphones with mounting accessories is supplied with the system. Boasting a linear frequency response from 100 Hz to 15 kHz (± 2 dB), the MSS6000 produces truly studio-quality sound.

Smart and easy handling

With its well designed road case and all cables included, you can easily take your Microphone Summation System with you wherever you go. Mounting the microphones and setting up the system is accomplished within minutes. Practical satellite box holders for attachment to music stands are available as optional accessories.

Also available without the ten 4061 microphones as MSS6000-E. An obvious choice in combination with other DPA microphones like the omnidirectional 4066 headbands or the supercardioid 4099 clip microphones.

MSS6000 includes

4061-BM	Miniature Microphone, 10 pcs	MHS6001	Mic. Holder for Strings, 10 pcs.
DAO0003	MSS6000 Cable 3 m (98 ft), 5 pcs.	MSB6000	Master Sum Box, 1 pcs.
DMM0007	Universal Surface Mount, 10 pcs.	SSB6000	Stereo Satellite Box, 5 pcs.
KE6000	Samsonite® Case		



DPA MSS6000 Key Features

- Sums 10 mics to two channels
- Modular system – flexibility to fit your needs
- Reduces cable clutter on stage
- Individual pan and level settings

DPA BLM4060 Boundary Layer Microphone

No boundaries

With its elegant design and excellent performance, the BLM4060 Boundary Layer Microphone is the perfect solution for capturing clear, natural speech and vocal sound reinforcement in boardrooms, courtrooms, classrooms and conference facilities. The BLM4060 is a transducer designed to work under optimum conditions when placed on hard, flat surfaces that reflect sound. Featuring a built-in DPA 4060 miniature microphone with an omnidirectional polar pattern, the BLM4060 benefits from the available wide range of connection adapters and power supplies that make it possible to be used with essentially any microphone input.

The microphone element is designed for maximum speech intelligibility and the microphone body consists of a center rubber disc that holds the microphone element mounted in an elegant stainless steel base. The BLM4060 can be easily placed in essentially any position on the surface, even close to the edge. Users will benefit from the special characteristics of the surrounding sound field on which the BLM4060 is mounted: a 6 dB gain of direct sound and only 3 dB gain of the diffuse sound.



DPA BLM4060 Key Features

- Excellent speech pickup
- Easily placed on all surfaces
- Stylish and elegant design
- Ideal choice for conference rooms

Adapters

Limitless connectivity

Have a specific wireless transmitter and bodypack that you prefer to use? No problem. Thanks to the innovative MicroDot connector design and nearly 40 available adapter accessories, DPA's miniature line of microphones can be used with practically every popular wireless system on the market.

Expand your arsenal

The versatile MicroDot solution effectively multiplies your microphone inventory. Using a DPA adapter you can use the same miniature microphone on nearly any professional wireless system available, plus on cable.

We play nice with everyone

DPA has specific adapters for AKG, Audio Ltd, Audio-Technica, Beyerdynamic, Electro-Voice, Lectrosonics, Micron, Mipro, Pastega, Telex ProStar, Ramsa, Samson, Sennheiser, Shure, Sony, Toa, Vega and other systems. Each adapter is guaranteed to perfectly mate to your system of choice.

Optimized XLR adapters

There are also a few varieties of MicroDot to 3-pin XLR adapters, such as the DAD6024, which provides a 3 dB attenuation at 800 Hz for added clarity when a miniature microphone is chest-worn. This electronic modification prevents the loss of presence, intelligibility and definition, as well as minimizes the need for equalization and additional tweaking.



Adapters - Using original DPA adapters, our miniature microphones are currently compatible with the professional transmitters listed below. The model number is typically found on the transmitter. * It is possible to order selected miniature microphone types with fixed connectors, see www.dpamicrophones.com/connectors

Brand / Transmitter	Adapter	Brand / Transmitter	Adapter
AKG PT 40	DAD3052	Sabine SW70-T	DAD3053
AKG PT 60	DAD6017*	Samson CT-2	DAD6009
AKG PT 80	DAD6017*	Samson TX-3	DAD6009
AKG PT 81	DAD6017*	Samson UT1L	DAD6017*
AKG PT 400	DAD6017*	Samson UT4	DAD6009
AKG PT 4000	DAD6017*	Samson UT5	DAD6009
Audio Ltd. Tx 2000	DAD6004*	Samson UT6	DAD6009
Audio Ltd. Tx 2020	DAD6004*	Samson VT2L	DAD6017*
Audio Ltd. Tx 2040	DAD6004*	Sennheiser BF1053-UJ	DAD6002
Audio Ltd. MiniTX	DAD6035	Sennheiser BF1083-UJ	DAD6002
Audio-Technica ATW-T51 (1400 ser.)	DAD6022	Sennheiser Evolution / G2 Series	DAD6034*
Audio-Technica ATW-T75 (7000 ser.)	DAD6028	Sennheiser SK 50	DAD6003*
Audio-Technica ATW-T101 (U100)	DAD6021	Sennheiser SK 250	DAD6003*
Audio-Technica ATW-T210	DAD6028	Sennheiser SK 3063	DAD6003*
Audio-Technica ATW-T310	DAD6033	Sennheiser SK 5012	DAD6003*
Audio-Technica ATW-T701	DAD6033	Shure PGX1	DAD6010*
Audio-Technica AEW-T1000	DAD6033	Shure SC1	DAD6010*
Audio-Technica ATW-T1000 D	DAD6033	Shure SLX1	DAD6010*
Beyerdynamic TS42	DAD6006	Shure U1	DAD6010*
Beyerdynamic TS85	DAD6006	Shure U1L	DAD6011
Beyerdynamic TS190	DAD6006	Shure U1LX1	DAD6010*
Beyerdynamic TS500	DAD6026	Shure UR1	DAD6010*
Beyerdynamic TS600	DAD6026	Shure UR1M Lemo3	DAD6003*
Beyerdynamic OPLUS 100-200	DAD6027	Shure UT1	DAD6010*
Beyerdynamic OPLUS 300	DAD6032	Sony DWT-B01 Digital Wireless	DAD3058
Beyerdynamic OPLUS 500	DAD6032	Sony Freedom WRT 805	DAD6019*
Beyerdynamic OPLUS 800	DAD6032	Sony WRT8	DAD6008*
Beyerdynamic OPLUS 900	DAD6032	Sony WRT820	DAD6008*
Electro-Voice CSB-1000 (RE1/RE2)	DAD6030	Sony WRT860	DAD6008*
Lectrosonics M185	DAD6012*	TELEX	DAD6030
Lectrosonics UHF (low level)	DAD6021*	Telex ProStar UHF UB12	DAD6020
Lectrosonics LM, SM and UM series	DAD3056*	TOA WM360	DAD3050
Micron TX501.x	DAD6013	TOA WM4300	DAD6010*
Micron TX502.x	DAD6013	TOA WM4310	DAD3050
Micron Explorer Series / TX700	DAD6025	Trantec S55 (UHF)	DAD6036
Mipro ACT-707T	DAD6032	Trantec S5000 Series	DAD6026
Mipro ACT-707TE	DAD6032	Trantec SD7000 Digital Wireless	DAD6003*
Mipro ACT-707TM	DAD6032	Vega T-37	DAD6015
Mipro ACT-707TS	DAD6032	Vega T-66	DAD6011
Mipro ACT-MT103	DAD6032	Vega T-677	DAD6011
Mipro ACT-MT303	DAD6032	Vega U2020	DAD6015
Mipro ACT-MT801	DAD6032	Wisicorn TMA16	DAD6018
Mipro ACT-MT808	DAD6032	Wisicorn TMU20	DAD6018
Mipro MR/812	DAD6023	X2 Digital Wireless Systems	DAD6034
Mipro MR/822	DAD6023	XLR adapter with belt clip	DAD6001-BC
Pastega TMA16	DAD6018	XLR adapter with midrange attenuator	DAD6024
Pastega TMU20	DAD6018	XLR adapter with belt clip and low cut	DAD4099
Ramsa WX-RP410	DAD3051	Zaxcom TRX900	DAD3057
Sabine SW16T	DAD6023		
Sabine SW30T	DAD6023		

DAD3050



TOA WM360/4310
(for low DC Microphones)
MicroDot to Mini-jack

DAD3051



Ramsa WX-RP410
(for low DC Microphones)
MicroDot to 4-pin Hirose

DAD3052



AKG PT 40
(for low DC Microphones)
MicroDot to TA3F Switchcraft

DAD3053



Sabine SW70-T
(for low DC Microphones)
MicroDot to TA4F Switchcraft

DAD3056



Lectrosonics LM, SM and UM series
(for low DC microphones)
MicroDot to TA5F Switchcraft

DAD3057



Zaxcom TRX900 Series
(for low DC microphones)
MicroDot to Lemo 3-pin

DAD3058



Sony DWF-B01
MicroDot to 4-pin Hirose

DAD4099



MicroDot to XLR Connector
with Belt Clip and Low-Cut Filter

DAD6001-BC



MicroDot to 3-pin XLR (P48)
with belt clip

DAD6002



Sennheiser BF1053-U/BF1083-U
MicroDot to Coax Lemo

DAD6003



Sennheiser SK 50/SK 250/SK 306/SK 502,
Trantec SD7000 Digital Wireless, Shure UR1M
Lemo3
MicroDot to 3-pin Lemo

DAD6004



Audio Ltd. Tx 2000/Tx 2020/ Tx 2040
MicroDot to 6-pin Lemo

DAD6006



Beyerdynamic TS42/TS85/TS190
MicroDot to 4-pin Binder

DAD6008



Sony WRT8/WRT820/WRT860
MicroDot to 4-pin Hirose

DAD6009



Samson CT-2/TX-3/UT4/UT5/UT6
MicroDot to 6-pin Hirose

DAD6010



Shure PGX1/SC1/SLX1/U1/ULX1/UR1/UT1,
TOA WM4300
MicroDot to TA4F Switchcraft

DAD6011

Vega T-66/T-677, Shure U1L
MicroDot to 4-pin Lemo Series 5

DAD6012

Lectrosonics M185
MicroDot to TA5F Switchcraft

DAD6013

Micron TX501.x/TX502.x
MicroDot to 8-pin Lemo

DAD6015

Vega T-37/UJ2020
MicroDot to TA4F Switchcraft

DAD6017

AKG PT 60/80/81/400/4000, Samson
UT1L/VT2L
MicroDot to TA3F Switchcraft

DAD6018

Wisycorn/Pastega TMA16/TMU20
(3 wire preset)
MicroDot to 3-pin Fischer

DAD6019

Sony Freedom WRT805,
MicroDot to Mini-jack (with thread)

DAD6020

Telex ProStar UHF-UB12
MicroDot to TA4F Switchcraft

DAD6021

AT ATW-T101 (U100), Lectrosonics UHF
systems for low level
MicroDot to TA5F Switchcraft

DAD6022

Audio-Technica ATW-51 (1400 series)
MicroDot to 4-pin Hirose

DAD6024

MicroDot to 3-pin XLR (P48)
w/ Midrange Attenuation
MicroDot to XLR

DAD6025

Micron Explorer Series/TX700
MicroDot to 6-pin Lemo Series B

DAD6026

Beyerdynamic TS 500/600, Trantec S5000
MicroDot to 4-pin Lemo

DAD6027

Beyerdynamic OPLUS 100-200
MicroDot to Mini-jack

DAD6028

Audio-Technica ATW175 (7000 Series)/
ATW1210
MicroDot to 4 pin Hirose.

DAD6030

Electro-Voice CSB-1000 (RE1/RE2), TELEX
MicroDot to TA4F Switchcraft

DAD6032



Beyerdynamic OPUS 300/500/800/900,
Mipro ACI-707I/TE/TM/TS/MT103/303
/801/808
MicroDot to TA4F Switchcraft

DAD6033



Audio-Technica ATWT310/ATWT701/
ATWT1000D/ATWT310/AEWT1000/
MicroDot to 4-pin Hirose

DAD6034



Sennheiser Evolution/G2 X2 Digital
Wireless Systems
MicroDot to Mini-jack (with thread)

DAD6035



Audio Ltd. Mini TX
MicroDot to 4-pin Lemo
(short version)

DAD6036



Trantec S55 (UHF)
MicroDot to TA4F Switchcraft.

Accessories

Something for everyone

Whether you spend most of your time in the studio, on stage, or in the field, DPA is constantly developing forward-thinking new accessory solutions to best meet your needs.

Serious attachment

Need just the right holder or mount to keep your miniature microphone in place? Simply take your pick from a wide variety of miniature clips, single and double pins, magnet mounts, universal surface mounts, miniature concealers, tie pods, mic holders for strings, double-sided adhesive pads, and more. Find that "sweet spot" and keep your microphone there.

Calm the storm

Five different colors of tiny foam windscreens sufficiently keep plosives under control, while a windjammer and miniature mesh allow engineers to very effectively reduce wind and handling noise.

Tiny power stations

Numerous options exist for powering DPA's range of miniature microphones. The MMA6000 high quality, two-channel microphone amplifier and power supply box for portable stereo recording is equipped with a pair of MicroDot input connectors, 16-position gain control, and low-cut filter. The aluminum tube-shaped MPS6001 can power a single miniature mic via a standard 1.5V AAA battery or work as a 48 V Phantom Power adapter. And several varieties of ultra-compact MPS series power supplies can provide more than 300 hours of high-fidelity continuous use from a single 9 V battery.

Instant modification

For head-worn applications, DPA offers an anodized steel grid that fits over many of its miniature microphones and introduces a 3 dB soft boost between 8 - 20 kHz. Similarly, another grid is also available that provides a 10 dB soft boost around 12 kHz for chest-worn use. These are both offered in a choice of colors.

Options galore

And there are plenty of other accessories available, including a variety of headbands to fit everyone from small children to towering adults, quality coaxial extension cables in a number of lengths, sweat stoppers, headband clips, and MicroDot tools, among others. There are even various accessory kits for specific applications – such as ENG/EFP and film – that conveniently package the most appropriate tools for the job in a sturdy case with a transparent lid.

DMM0001



Miniature Clip

DMM0002-B/W



Miniature Double Pin, Black or White

DMM0003-B/W



Miniature Magnet, Black or White

DMM0004-B/W



Miniature Clip, Small, Black or White

DMM0005



Miniature Holder, Single Pin, 3 pcs.

DMM0007



Universal Surface Mount, 5 pcs.

DMM0008-B/W



Miniature Clip, Double Lock, Black or White

DMM0009



Miniature Concealer for 4071

DMM0010



Tie Pod, 3 pcs.

DMM0011-B/W



Magnet Mount, Black or White

DMM0012



Miniature Concealer for 4060

DMM0014



Clip for 4080

DMM0015



Double Clip for 4080

DMM0016



Magnet Mount for 4080

DUA0513



Cable clamp for 4080, 5 pcs.

MHS6001



Microphone Holder for Strings

DUA6001/03/05/17

Miniature Grids, Soft Boost, Black, Beige, White & Brown, 5 pcs.

DUA6002/04/06/18

Miniature Grids, High Boost, Black, Beige, White & Brown, 5 pcs.

DUA0574/75/76

Pop Screens for 4088, Black, Beige & Brown

DUA6019

Protection Cap for 4060/61/62/63/65/66/67/71/73, 25 pcs.

DUA0560/61/62/63/64/66/67/68/70

Windscreens, Black, Red, Blue, Yellow, Green, White, Beige, Brown & Colormix

DUA0571

Windjammer for 4071, Grey Fur

DUA0572

Miniature Mesh for 4071

DUA0577

Windscreen for 4080

DAK4060

Accessory Kit for Miniature Microphones

DAK4071-E

Accessory Kit for Miniature Microphones - ENG/EFP

DAK4071-F

Accessory Kit for Miniature Microphones - Film

ADH0001

Double-sided Tape for Tie Pod, 25 pcs.

ADH0002

Double-sided Tape for Miniature Microphones Concealer, 25 pcs.

ADH0003

Miniature Mic Tape, 25 pcs.

ADH0004/05

Double-sided Mic Tape, 10 pcs.
Double-sided Mic Tape, 50 pcs.

DAO6005

Miniature Microphone Extension Cable, 35 m (115 ft)

DAO6010

Miniature Microphone Extension
Cable, 10 m (328 ft)

DAO6020

Miniature Microphone Extension
Cable, 20 m (656 ft)

DAO6015

Cable for BLM4060, 3 m (10 ft)

DAO6016

Cable for BLM4060, 10 m (328 ft)

DAO6017

Cable for BLM4060, 20 m (656 ft)

DAO0135

Stereo Mini-jack Plug, 1 m (3 ft)

DAO0136

Stereo Mini-jack Plug - 2 x 1/4 in
Mono Jack Plugs, 5 m (164 ft)

DAO0137

Stereo Mini-jack Plug - 1/4 in
Mono Jack Plug, 5 m (164 ft)

DAO0138

Stereo Mini-jack Plug - 2 x male XLR
Plugs, 5 m (164 ft)

DAO0139

Stereo Mini-jack Plug - Phono L+R Plug,
1 m (3 ft)

MMA6000

Miniature Microphone Amplifier

MPS6001

Miniature Power Supply, 1-channel,
3-pin XLR

MPS6010

Miniature Power Supply, 2-channel,
3-pin XLR

MPS6020

Miniature Power Supply, 2-channel, Phono

MPS6030

Miniature Power Supply, 2-channel,
Stereo Mini-jack

MPS6040

Miniature Power Supply, 2-channel,
1/4 in Stereo Jack

MSB6000



Master Sum Box

SSB6000



Stereo Satellite Box

AHM6000



Adjustable Headband Mount, Beige,
small, medium or large

AHM6001



Adjustable Headband Mount, Black,
small, medium or large

MMB4066-B



Miniature Microphone Boom, Omni, Black

MMB4066-C



Miniature Microphone Boom, Omni, Brown

MMB4066-F



Miniature Microphone Boom, Omni, Beige

MMB4088-B



Miniature Microphone Boom,
Cardioid, Black

MMB4088-C



Miniature Microphone Boom,
Cardioid, Brown

MMB4088-F



Miniature Microphone Boom,
Cardioid, Beige

Specifications for DPA 4060, 4061, 4062, 4063, 4065, 4066 & 4067

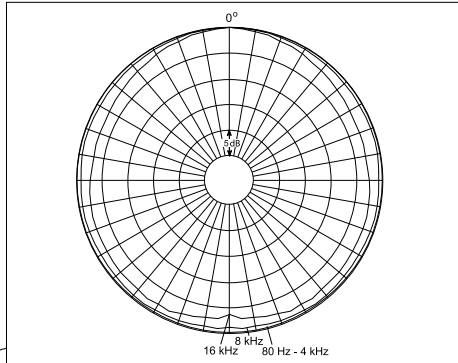

Polar Pattern

Directional characteristics of the 4060 (normalized).

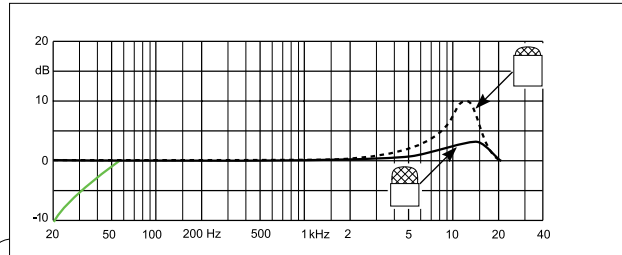

On-Axis Frequency Response of Miniature Microphones

Dotted line is with high boost grid. Solid line is with soft boost grid. Green line is 4067 below 50 Hz. (4065 only utilizes the soft boost frequency response).

Directional characteristics

Omnidirectional

Principle of operation

Pressure

Cartridge type

Pre-polarized condenser element with vertical diaphragm

Frequency range, ± 2 dB

Soft boost grid: 20 Hz – 20 kHz, 3 dB soft boost at 8 – 20 kHz

High boost grid: 20 Hz – 20 kHz, 10 dB boost at 12 kHz

4067: 50 Hz – 20 kHz, Low-cut: -10 dB at 20 Hz

Sensitivity, nominal ± 3 dB at 1 kHz

4060: 20 mV/Pa; -34 dB re. 1 V/Pa

4061/4063/4065/4066: 6 mV/Pa; -44 dB re. 1 V/Pa

4062/4067: 1 mV/Pa; -60 dB re. 1 V/Pa

Equivalent noise level, A-weighted

4060: Typ. 23 dB(A) re. 20 μ Pa (max. 26 dB(A))

4061/4063/4065/4066: Typ. 26 dB(A) re. 20 μ Pa (max. 28 dB(A))

4062/4067: Typ. 33 dB(A) re. 20 μ Pa (max. 37 dB(A))

Equivalent noise level ITU-R BS.468-4

4060: Typ. 35 dB (max. 38 dB)

4061/4063/4065/4066: Typ. 38 dB (max. 40 dB)

4062/4067: Typ. 45 dB (max. 49 dB)

Polarity

Positively increasing sound pressure produces positive going voltage on MicroDot pin.

S/N ratio, (A-weighted) re. 1 kHz at 1 Pa (94 dB SPL)

4060: 71 dB(A)

4061/4063/4065/4066: 68 dB(A)

4062/4067: 61 dB(A)

Total Harmonic Distortion (THD)

<1% THD up to 123 dB SPL peak

<1% THD up to 120 dB SPL RMS sine

Dynamic range

4060: Typ. 100 dB

4061/4063/4065/4066: Typ. 97 dB

4062/4067: Typ. 90 dB

Max. SPL, peak before clipping

4060:	134 dB
4061/4065/4066:	144 dB
4062/4067:	154 dB
4063:	138 dB

Output impedance

30 – 40 ohm

Cable drive capability

Up to 300 m (984 ft)

Power supply

For wireless systems:

Min. 5 V – max. 50 V through DPA adapter

4063/4067: Min. 3 V – max. 50 V

With DAD6001-BC/DAD6024/DAD4099:

48 V phantom power ± 4 V for full performance

Connector

MicroDot

Color

4060/4061/4063: Black, beige, brown or white

4062/4066/4067: Black, brown or beige

4065: Black or beige

Dimensions

Weight: 4060/4061/4062/4063: 75 g (0.26 oz) incl. cable and MicroDot connector; 4065/4066/4067: 14 g (0.50 oz) incl. cable and MicroDot connector

Microphone diameter: 54 mm (0.21 in)

Microphone length: Max. 127 mm (0.5 in)

Cable

Cable length:

4060/4061/4062/4063: 18 m (59 ft)

4065/4066/4067: 12 m (39 ft)

SMK4060/4061: 3 m (11.8 ft)

Cable diameter: 1.6 mm (0.06 in)

Operating temperature range

-10 to 45° C (+14 to 113° F)

Specifications for DPA 4071 & 4073

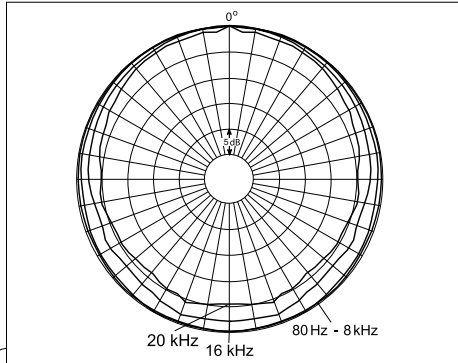

Polar Pattern

Directional characteristics of DPA 4071 (normalized).

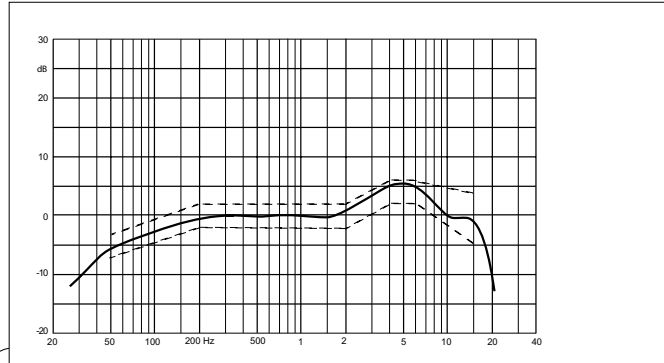

Frequency Response

Typ. on-axis frequency response of DPA 4071 with tolerance field.

Directional characteristics

Omnidirectional

Principle of operation

Pressure

Cartridge type

Pre-polarized condenser element with vertical diaphragm

Frequency range, ± 2 dB

100 Hz – 15 kHz with typ. 5 dB soft boost at 4 – 6 kHz.

Sensitivity, nominal ± 3 dB at 1 kHz

6 mV/Pa; -44 dB re. 1 V/Pa

Equivalent noise level, A-weighted

Typ. 26 dB(A) re. 20 μ Pa (max. 28 dB(A))

Equivalent noise level ITU-R BS.468-4

Typ. 38 dB (max. 40 dB)

S/N ratio, (A-weighted) re. 1 kHz at 1 Pa (94 dB SPL)

68 dB(A)

Total Harmonic Distortion (THD)

<1% up to 123 dB SPL peak

<1% up to 120 dB SPL RMS sine

Dynamic range

Typ. 97 dB

Max. SPL, peak, before clipping

144 dB

Output impedance

30 – 40 ohm

Cable drive capability

Up to 300 m (984 ft)

Power supply

For wireless systems: Min. 5 V – max. 50 V through DPA adapter

4073: Min. 3 V – max. 50 V

With DAD6001-BC/DAD6024/DAD4099:

48 V phantom power ± 4 V for full performance

Connector

MicroDot

Color

4071: Black, beige or white

4073: Black

Dimensions

Microphone length: 17 mm (0.67 in)

Microphone diameter: 54 mm (0.21 in)

Weight: 9 g (0.32 oz) incl. cable and MicroDot connector

Cable

Cable length: 1.8 m (59 ft)

Cable diameter: 1.6 mm (0.06 in)

Polarity

Positively increasing sound pressure produces

positive going voltage on MicroDot pin.

Operating temperature range

-10 to 45° C (+14 to 113° F)

Specifications for DPA 4080

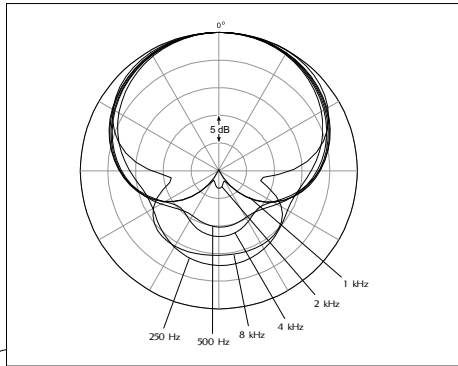

Polar Pattern

Directional characteristics of 4080 (normalized).

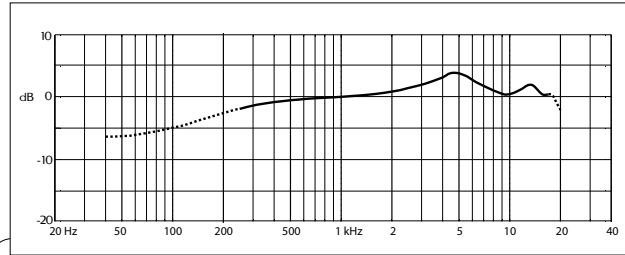

Frequency Response

On-axis response of 4080 measured at 25 cm (10 in).

Directional characteristics

Cardioid

Principle of operation

Pressure gradient

Cartridge type

Pre-polarized condenser element with vertical diaphragm

Frequency range ± 2 dB

250 Hz – 17 kHz with typ. 4 dB soft boost at 4 – 6 kHz (-5 dB at 100 Hz)

Sensitivity, nominal, ± 3 dB at 1 kHz

20 mV/Pa; -34 dB re. 1 V/Pa

Equivalent noise level, A-weighted

Typ. 23 dB(A) re. 20 μ Pa (max. 26 dB(A))

S/N ratio (A-weighted), re. 1 kHz at 1 Pa (94 dB SPL)

Typ. 71 dB (A)

Total Harmonic Distortion (THD)

<1 % up to 123 dB SPL peak

<1 % up to 120 dB SPL RMS sine

Dynamic range

Typ. 100 dB

Max. SPL, peak before clipping

144 dB

Output impedance

30 – 40 ohm

Cable drive capability

Up to 300 m (984 ft)

Power supply

For wireless systems: Min 5 V – max. 50 V through DPA adapter

With DAD6001-BC/DAD6024/DAD4099:

48 V phantom power ± 4 V for full performance

Connector

MicroDot

Dimensions

Microphone length: 30 mm (1.2 in)

Microphone diameter: 10 mm (0.4 in)

Capsule diameter: 54 mm (0.2 in)

Weight: 15 g (0.5 oz) incl. cable and MicroDot connector

Cable

Cable length 1.2 m (4 ft)

Cable diameter: 1.6 mm (0.06 in)

Polarity

Positively increasing sound pressure produces positive going voltage on MicroDot pin

Specifications for DPA 4088

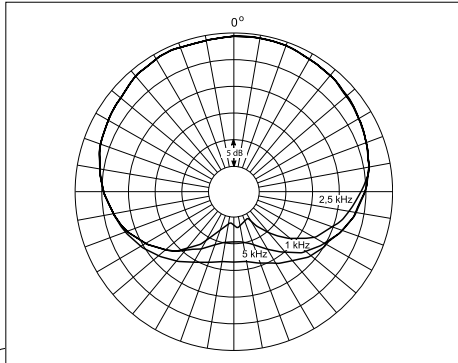

Polar Pattern

Directional characteristics of DPA 4088 (normalized).

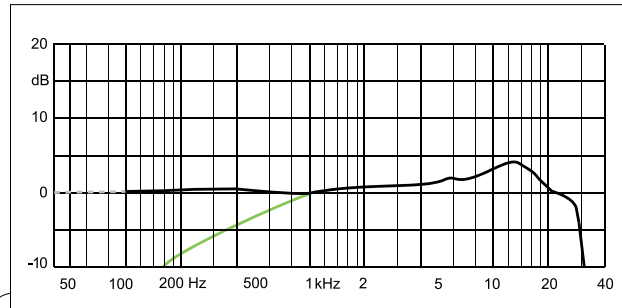

On-Axis Frequency Response of 4088

Solid line is near field (2 – 3 cm). Green line is far field (more than 30 cm). Dotted line is typical low frequency in near field (estimated).

Directional characteristics

Cardioid

Principle of operation

Pressure gradient

Cartridge type

Pre-polarized condenser element with vertical diaphragm

Frequency range, ± 2 dB

100 Hz – 20 kHz (4 – 6 dB soft boost at 15 kHz)

Sensitivity, nominal ± 3 dB at 1 kHz

6 mV/Pa; -44 dB re. 1 V/Pa

Equivalent noise level, A-weighted

Typ. 26 dB(A) re. 20 μ Pa (max. 28 dB(A))

Equivalent noise level ITU-R BS.468-4

Typ. 38 dB (max. 40 dB)

S/N ratio, (A-weighted) re. 1 kHz at 1 Pa (94 dB SPL)

68 dB(A)

Total Harmonic Distortion (THD)

<1 % up to 123 dB SPL peak

<1 % up to 120 dB SPL RMS sine

Polarity

Positively increasing sound pressure produces positive going voltage on

MicroDot pin.

Dynamic range

Typ. 97 dB

Max. SPL, peak before clipping

144 dB

Output impedance

30 – 40 ohm

Cable drive capability

Up to 300 m (984 ft)

Power supply

For wireless systems: Min. 5 V – max. 50 V through DPA adapter

With DAD6001-BC/DAD6024/DAD4099:

48 V phantom power ± 4 V for full performance

Connector

MicroDot

Color

Black, brown or beige

Dimensions

Weight: 14 g (0.5 oz) incl. cable and MicroDot connector

Microphone diameter: 55 mm (0.25 in)

Microphone length: 11 mm (0.5 in)

Cable

Cable length: 1.2 m (39 ft)

Cable diameter: 1.6 mm (0.06 in)

Operating temperature range

-10 to 45° C (+14 to 113° F)

Specifications for DPA MSS6000

SSB6000 Stereo Satellite Box

Inputs

Microphone input, two channels with MicroDot connector, one 4-pin female XLR for connecting to another SSB6000.

Output

One 4-pin male XLR for connecting to the MSB6000 Master Sum Box or another SSB6000.

Frequency range

100 Hz – 10 kHz (-3 dB) with Soft Boost Grid on DPA 4061

100 Hz – 15 kHz (-3 dB) with High Boost Grid on DPA 4061

High-cut: -6 dB/oct. from 10 kHz

Low-cut: -6 dB/oct. from 100 Hz

Max SPL input handling

System unloaded: 134 dB

System loaded: 128 dB (10 pcs. DPA 4061)

Attenuation

35 dB to ∞ , each channel

Microphone input impedance

1.8 kilohm

Dimensions

95 x 104 x 34 mm (3.75 x 4.1 x 1.4 in)

Weight

245 g (7.9 oz)

MSB6000 Master Sum Box

Input

Single 4-pin female XLR for connecting to the SSB6000

Outputs

Dual 3-pin male XLR, two channel microphone outputs

Power supply

48 V phantom, applied simultaneously to the two microphone outputs

Output impedance

Lundahl® output transformer, < 600 ohm

Total Harmonic Distortion (THD)

0.05% (100 Hz – 10 kHz)

Crosstalk

-70 dB at 1 kHz

Cable drive capability

200 m (656 ft)

Dimensions

120 x 104 x 34 mm (4.7 x 4.1 x 1.4 in)

Weight

400 g (14 oz)

4061 Miniature Omnidirectional Microphone

See page 32

Specifications for DPA BLM4060

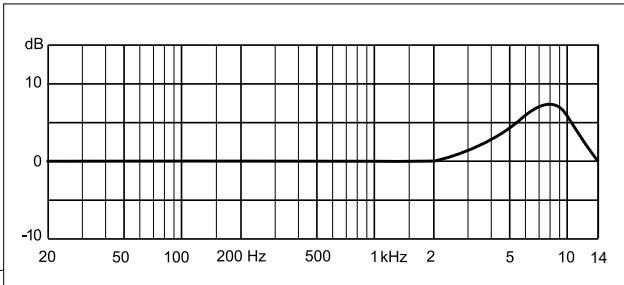

On-Axis Frequency Response of BLM4060

Directional characteristics

Omnidirectional, hemisphere

Principle of operation

Pressure

Cartridge type

Pre-polarized condenser element

Frequency range, ± 2 dB

20 Hz – 14 kHz

(with a 7 dB soft boost at 8 kHz)

Sensitivity, nominal ± 3 dB at 1 kHz

20 mV/Pa -34 dB re. 1 V/Pa

Equivalent noise level, A-weighted

Typ. 23 dB(A) re. 20 μ Pa (max. 26 dB(A))

Equivalent noise level ITU-R B5.468-4

Typ. 35 dB (max. 38 dB)

S/N ratio, (A-weighted) re. 1 kHz at Pa (94 dB SPL)

71 dB(A)

Total Harmonic Distortion (THD)

<1% up to 123 dB SPL peak

<1% up to 120 dB SPL RMS sine

Dynamic range

Typ. 100 dB

Max. SPL, peak before clipping

134 dB

Output impedance

From MicroDot: 30 – 40 ohm

From DAD6001: 100 ohm

Cable drive capability

Up to 300 m (984 ft)

Power supply

For wireless systems: Min. 5 V – max. 50 V through DPA adapter

With DAD6001-BC/DAD6024/DAD4099:

48 V phantom power ± 4 V for full performance

Connector

MicroDot/XLR 3-pin

Finish

Black rubber disc mounted in stainless steel base

Dimensions

Diameter: 100 mm (4 in)

Height: 12 mm (0.5 in)

Weight: 240 g (8.5 oz) excl. cable

Cable

Cable length: 3 m (10 ft)

Cable diameter: 1.6 mm (0.06 in)

Cable color: Black

Polarity

Positively increasing sound pressure produces

positive going voltage on MicroDot pin/pin2 on XLR connector

Operating temperature range

-10 to 45° C (+14 to 113° F)

Other brochures by DPA Microphones available to order or download from our website



Live Instrument Microphones

The DPA 4090, 4091, 4099 and mounting systems are meticulously designed and optimized for a wide range of instruments. This is to ensure the best possible mount and audio reinforcement is achieved when performing live.

Compact Microphones

The choice of musicians for maximum clarity. Specifically designed to satisfy the demands of professionals, the DPA Compact Mics offer ingenious mounting solutions as well as sonic excellence.



Standard Microphones

High quality studio microphones that deliver a totally faithful reproduction of the original sound with state-of-the-art components carefully selected to provide optimal neutrality, accuracy, and extremely low distortion.

Surround Sound Solutions

The DPA surround product range encompasses a plug-and-play mobile surround microphone, versatile and stylish mounts, and surround matched mics that can accommodate today's high-resolution digital formats.



DPA 
MICROPHONES

DPA 
MICROPHONES

WWW.DPAMICROPHONES.COM



Head Office

DPA Microphones A/S
 Gydevang 42-44
 DK-3450 Allerød, Denmark
 Tel: +45 4814 2828
 Fax: +45 4814 2700
 info@dpamicrophones.com
 www.dpamicrophones.com

US Sales Office

DPA Microphones, Inc.
 2432 N. Main St., Suite 200
 Longmont, CO 80501, USA
 Tel: +1 303 485 1025
 Fax: +1 303 485 6470
 info-usa@dpamicrophones.com
 www.dpamicrophones.com