



# NYX BULB

Full-color LED bulb for film productions & event lighting. Accepts AC power via lamp socket as well as DC power from power banks and other external batteries.



## SPECIFICATIONS



App



Wireless DMX



### Dual Power Input

Power through E27/E26 AC socket or external (standard power bank or PowerStation)



Order Code	FP5-E27 / FP5-E26 / FP5-B22 FP5-E27-B / FP5-E26-B / FP5-B22-B
Colors	RGBMintAmber
Total LED Power / Power Draw	14W / 10W
Luminous Flux*	750lm (@4000k)
CRI(RA)/TLCI 3200-6500k*	≥96
Strobe	0 - 25 Hz
Battery	only external
AC Power input E27	100-240V 50/60 Hz via E27 socket
AC Power input E26	100-120V 50/60 Hz via E26 socket
DC Power input	5-18V at 2.1A
Wired DMX	No
CRMX Receiver	Built in
Wireless Frequencies	CRMX 2.4GHz, UHF, Bluetooth LE 5.0
Range	UHF/CRMX: 100m/110yd; Bluetooth: 3m/3yd
Dimensions (mm/inches)	Ø70 x 130 / Ø2.76 x 5.12
Weight (kg/lbs)	0.24 / 0.53
Ingress Protection	IP44: connected via AC + Rubberplug in DC socket IP20: connected via DC socket

\*Typical value

## ACCESSORIES



INCLUDED

**USB DC Cable**  
FP5-USBC



**CupBouncer**  
FP5-CPB



**PowerStation**  
FP5-PS



**NYX Bulb Case**  
FP5-CSE

# TYPICAL SPECTRAS OF NYX BULB

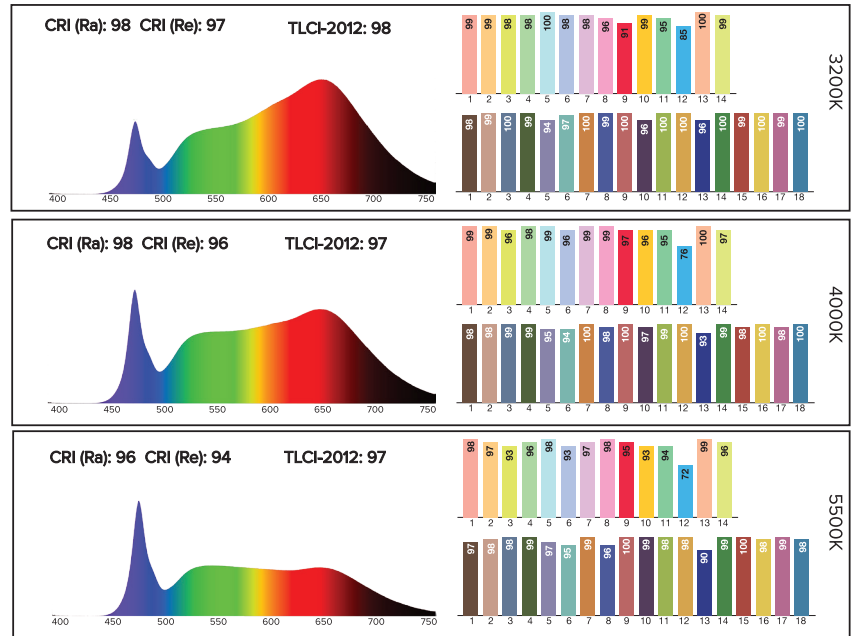

Typical values

## LIGHT DISTRIBUTION CURVE with CupBouncer

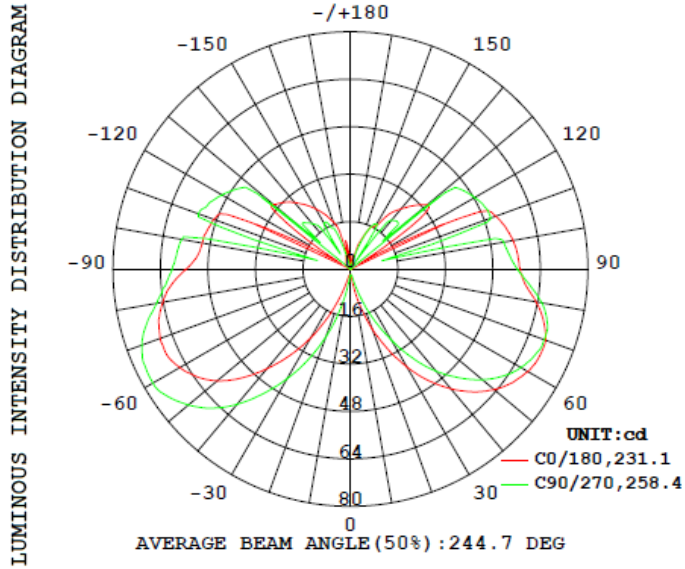

## without CupBouncer

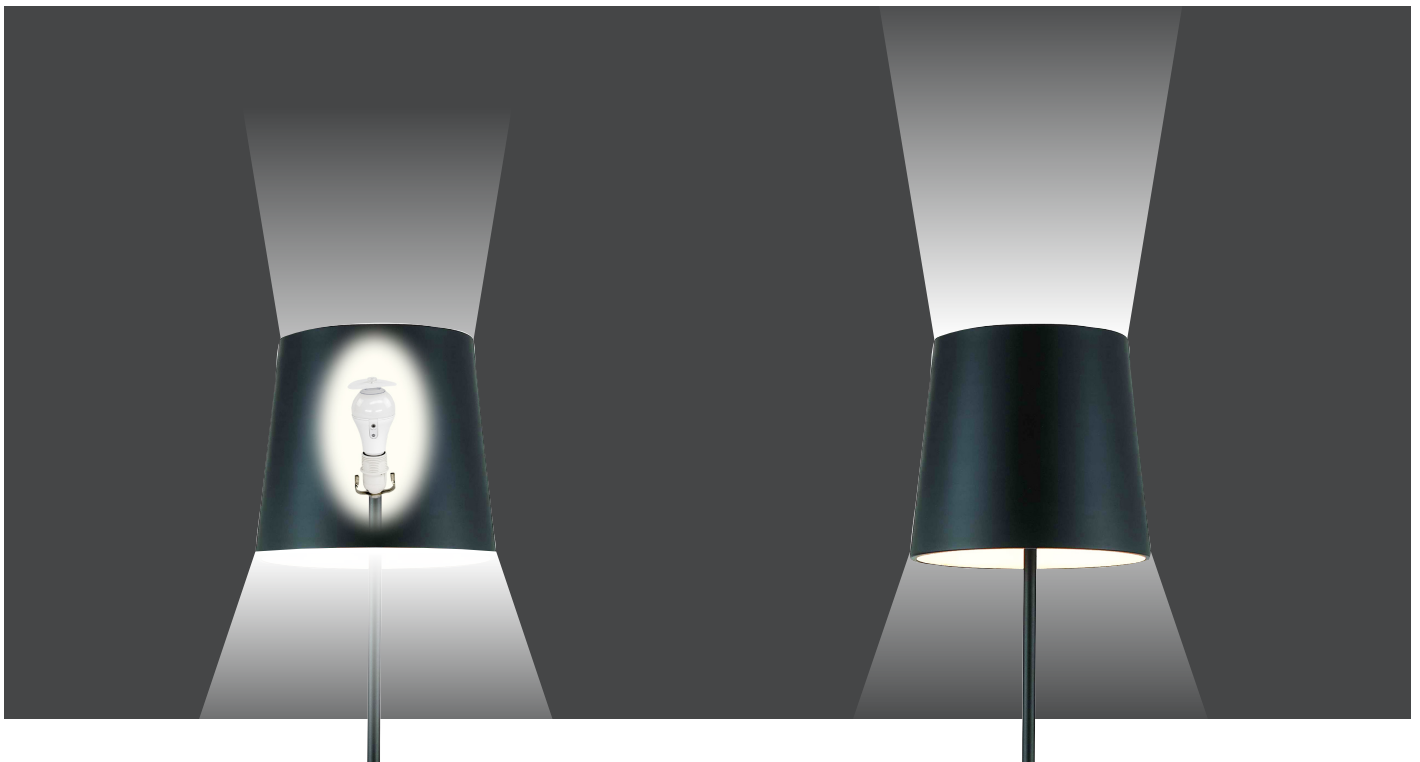
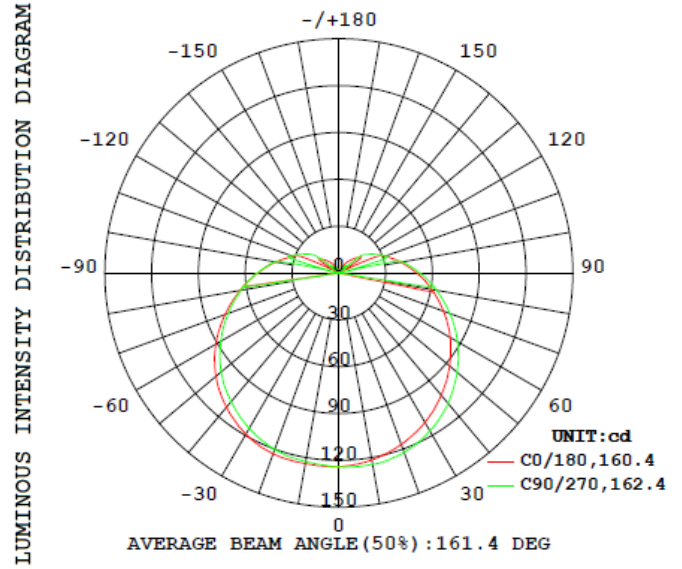

# RF CHARACTERISTICS

Wireless Modules	EU: UHF (863-870MHz)	USA: UHF (917-922.20MHz)	AUS: UHF (922.30-927.50MHz)	SGP: UHF (920.50-924.50MHz)
Modulation	FHSS	FHSS	FHSS	FHSS
ERP (Transmitter)	<25mW	<25mW	<25mW	<25mW
Channel Count	47	53	53	41

Wireless Modules	KOR: UHF (917.9-921.5MHz)	RUS: UHF (868.75-869.12MHz)	JPN: UHF (922.80-926.40MHz)	CRMX (2402-2480MHz)	Bluetooth 5.0 LE (2402-2480MHz)
Modulation	FHSS	FHSS	FHSS	FHSS	FHSS
ERP (Transmitter)	<25mW	<25mW	<25mW	<100mW	10mW (BLE)
Channel Count	10	6	19	79	40

## DRAWINGS

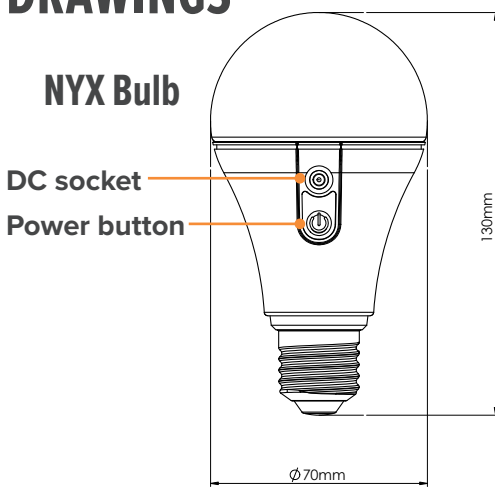

## CupBouncer

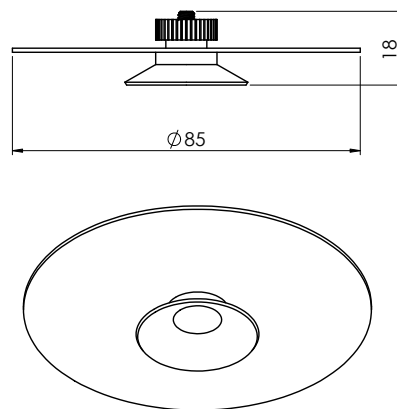

## USB Cable

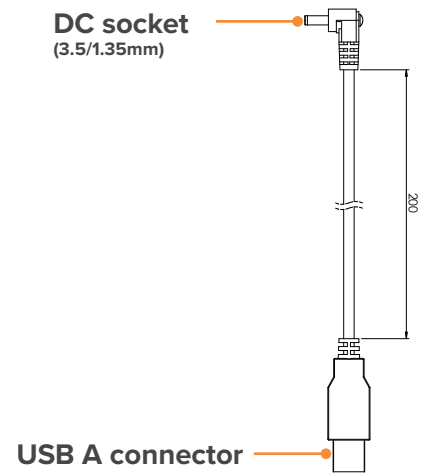

## NYX BULB AS TRANSMITTER

Connect directly to a NYX Bulb via Bluetooth. This Master light will revert AsteraApp commands to all other NYX Bulbs and other Astera lights via UHF band.

**AVAILABLE NOW VIA  
SOFTWARE-UPDATE**



# POWERSTATION

Connect the integrated cable to your bulb's DC connector to power it up. While connected, the PowerStation acts as a remote display to program DMX addresses and settings which the bulb will store in its memory. It can also set colors, effects, brightness etc which the bulb will continue to display when in a powered lamp socket or connected to a power bank. Apart from its backside magnets the PowerStation features an airline track to attach mounting accessories such as TrackPin and PowerStationHanger.



## SPECIFICATIONS

Order Code	FP5-PS-EU; FP5-PS-US; FP5-PS-UK; FP5-PS-CH; FP5-PS-AU
Power IN	24-48V
Power OUT	15V 0.7A
Battery	3350mAh/10.8V*
Charging time (nominal)	5h
Dimensions (mm / inch)	96 x 80.8 x 42.4 / 3.8 x 3.2 x 1.7
Weight (kg/lbs)	0.4 / 0.89

\*equivalent to a high quality power bank with 10.000mAh

## DRAWINGS

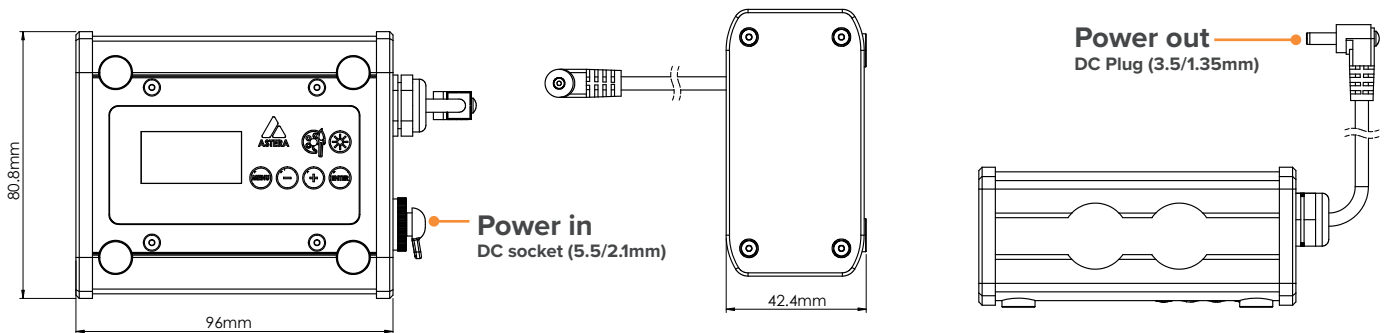

## ACCESSORIES



**Power Supply Unit**  
AX1-CHR

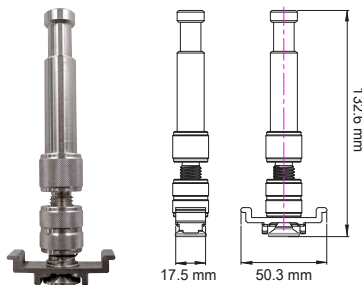

**TrackPin**  
AX-TP

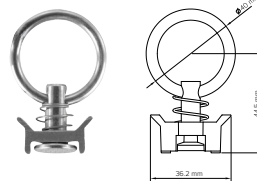

**PowerStation Hanger**  
FP5-PSH



**PowerStation Charging Case**  
FP5-PS-CHRCSE

included with each single FP5-PS



**Lamp Socket**  
FP5-E27S

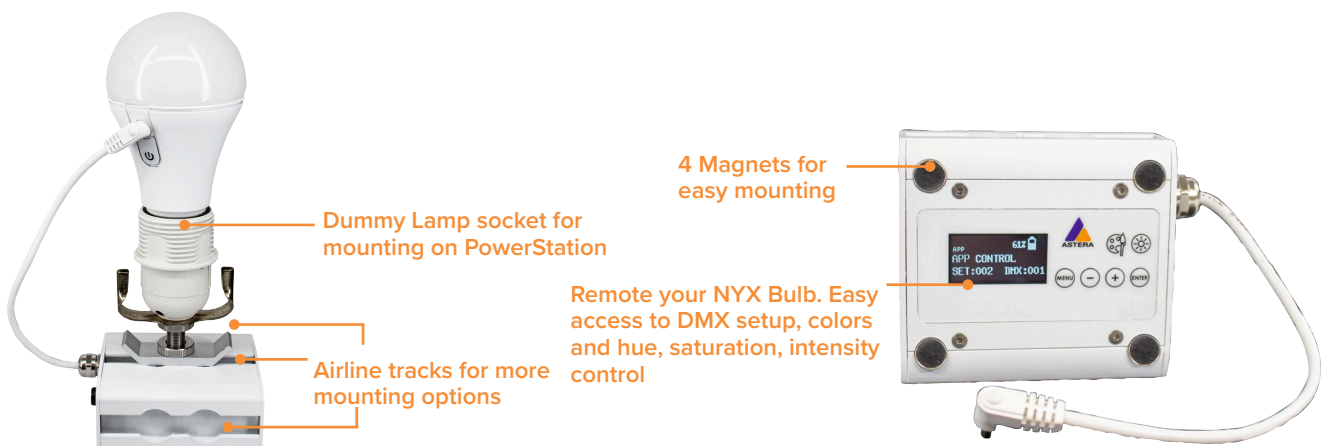

# SETS



## NYX BULB SET

414 x 334 x 130 mm

16.3 x 13.1 x 5.1 inches

5.3 kg/11.7 lbs (full weight)

FP5-E27-SET; FP5-E26-SET

### 8x NYX Bulb

1x PSU



1x Power Station



8x USB Cable



8x Cup-Bouncer



## POWERSTATION SET

520 x 400 x 140 mm

20.5 x 15.7 x 5.5 inches

8,5 kg/18.7 lbs (full weight)

FP5-PS-SET-EU; -US; -UK; -CH; -AU

### 8x PowerStation

8x PowerStation Hanger



8x TrackPin

8x Lamp Socket



1x DC Split Cable



1x PSU



8x Bridgecable



Charge PowerStations  
directly in the case.

# SETS - PROGRAMING

Program NYX Bulbs with the included PowerStation one by one.



Connect the 8 Powerstations with Bridge Cables to the 8 NYX Bulbs for setting them up all together.

Find the latest version of this datasheet on [www.astera-led.com/nyx/](http://www.astera-led.com/nyx/)