

Robotic and Manual Pan and Tilt Heads

FH155 Manual

FH155 Manual StarTracker

FH155 Manual VR

FH155 Manual VR StarTracker

FHR155 Robotic

FHR155 Robotic StarTracker

FHR155 Robotic VR

FHR155 Robotic VR StarTracker



Part No. V4155-0001
V4155-0002
V4155-0003
V4155-0004

Part No. V4155-0011
V4155-0012
V4155-0013
V4155-0014

Copyright © 2019

All rights reserved.

Original Instructions: English

All rights reserved throughout the world. No part of this publication may be stored in a retrieval system, transmitted, copied or reproduced in any way, including, but not limited to, photocopy, photograph, magnetic or other record without the prior agreement and permission in writing of the Vitec Group Plc.

Disclaimer

The information contained in this publication is believed to be correct at the time of printing. Vitec Production Solutions Ltd reserves the right to make changes to the information or specifications without obligation to notify any person of such revision or changes. Changes will be incorporated in new versions of the publication.

We are making every effort to ensure that our publications are updated on a regular basis to reflect changes to product specifications and features. Should this publication not contain information on the core functionality of your product, please let us know. You may be able to access the latest revision of this publication from our website.

Vitec Production Solutions Ltd reserves the right to make changes to product design and functionality without notification.

Trademarks

All product trademarks and registered trademarks are the property of The Vitec Group Plc.

All other trademarks and registered trademarks are the property of their respective companies.

Published by:

Vitec Production Solutions Ltd

Supports Technical Publications Department

Email: technical.publications@vitecgroup.com

Safety and Warnings	2	Regular Checks	19
Components and Connections	6	Routine Use	19
Box Contents	7	Cleaning	19
Installation	8	Maintenance	19
Mounting Supports and Adaptors	8	Changing the Fuse	19
Cable Management Brackets	8	Troubleshooting	20
Mounting the Pan Bar Assembly (FH-155)	9	Specifications	21
HD Tripod Mounting Options	9	General Notes	22
Mitchell Centre Screw (3724-3)	10	General Purpose Connector	22
Quickfix Adaptor (V4096-1013)	10	Compliance	22
Locking / Unlocking the Camera Cradle	11	Declaration of Conformity	22
Adjusting the Camera Cradle	11		
Adjusting the Horizon Level	13		
Mounting the Camera	13		
Balancing the Head	14		
Setting the Fore / Aft Balance	14		
Adjusting the Centre of Gravity (C of G)	15		
Electrical Connections	16		
Cable Management	17		
Powering Up	17		
Configuring the Head	17		
Operation	18		
Manual Mode (FH models only)	18		
Switching to Manual	18		
Operating the Drags	18		

Safety and Warnings

Important information on the safe installation and operation of the product. Read this information before operating the product. For your personal safety, read these instructions. Do not operate the product if you do not understand how to use it safely. Save these instructions for future reference.

Warning symbols used in these instructions

Safety cautions are used in these instructions. These safety instructions must be followed to avoid possible personal injury and possible damage to the product.



WARNING! Where there is a risk of personal injury or injury to others, comments appear supported by the warning triangle symbol. Where there is a risk of damage to the product, associated equipment, process or surroundings, comments appear supported by the word 'CAUTION'.



ELECTRIC SHOCK Where there is a risk of electric shock, comments appear supported by the hazardous voltage warning triangle.



WARNING! Unexpected movement may occur. Risk of trapped hand / fingers.



CAUTION Please refer to the user guide for further information

Health and Safety



WARNING! Risk of personal injury or injury to others. All personnel must be fully trained and adhere to correct manual handling techniques and Health & Safety regulations. It is the responsibility of the local organisation to enforce safe working practs at all times.



Follow all warnings and instructions marked on the product and in this manual. Safety warnings are included in this manual. These safety instructions must be followed to avoid possible personal injury and damage to the product.



WARNING! Do not install this product onto a bracket, support or other equipment that is not designed to support the weight of the product and its payload. All supports must comply with local government regulations.



WARNING! The fitting of non-approved parts and accessories, or the carrying out of non-approved alterations or servicing can be dangerous and could affect the safety of the product. It may also invalidate the terms and conditions of the product warranty.



WARNING! Risk of personal injury or injury to others. All personnel must be fully trained and adhere to local health and safety laws and guidelines. It is the responsibility of the local organisation to enforce safe working practs at all times.



CAUTION! FHR Models:

These products are designed for robotic use only and are operated remotely. Do not attempt to operate these products manually.

Electrical Connections



WARNING! This product must be connected to a power supply of the same voltage (V) and current (A) as indicated on the product and described in the Technical Specifications section of this manual. To reduce the risk of electric shock, do not remove the covers.

No user servable parts inside. Refer all servicing to qualified serv personnel.



WARNING! The IEC connector is the primary disconnect dev and must be accessible both during and after installation of the product.



WARNING! Inspect the AC cable regularly for signs of wear or damage. If the AC cable is damaged, the product must be returned to Vinten for repair.



CAUTION! Only use the power cable specified for the products and certified for the country of use.

Supplied power cable V4101-5008



CAUTION! Using alternative cables will invalidate the system EMC liability and product warranty.

Supplied power cable V4101-5008



WARNING! When wiring directly to a studio power supply, the product must be connected to a switched 3A fused outlet.



WARNING! This product is Class 1 equipment. For safe operation this equipment must be connected to a power supply that has a protective earth connection (US: ground).

Operating Environment



CAUTION! The product should not be used outside the operating temperature limits. Refer to the product technical specifications for the operating limits for the product.



WARNING! This product is designed for Indoor use only. Do **Not** use outdoors.

Mounting and Installation



WARNING! Always ensure that all power and auxiliary communications cables are routed so that they do not present any danger to personnel. Take care when routing cables in areas where robotic equipment is in use.

Ventilation and Overheating



CAUTION! Slots and openings are intended for ventilation purposes to ensure reliable operation of the product and protect it from overheating. Do not block or cover any slots or openings.

Cleaning and Maintenance



CAUTION! Do not use solvent or oil-based cleaners, abrasives or wire brushes to remove accumulations of dirt as these damage the protective surfaces. To clean mechanical surfaces, use only detergent-based cleaners



CAUTION! Do not use oil or grease on any exposed part of the product. This is unnecessary and traps dirt which acts as an abrasive



WARNING! The tilt lock **MUST** be engaged whenever the head is lifted or transported and before installing or adjusting the camera or payload.



CAUTION! Risk of damage to equipment. Do not lift or carry the head by the back cover.



WARNING! Risk of electric shock. Always disconnect and isolate the product from the power supply before cleaning.

Safety and Warnings

Intended Use

This product is designed for use within video production studios to support and balance a camera together with ancillary equipment weighing up to 70 kg (154 lb). Camera operators can remotely control the head pan and tilt axes, and the lens zoom and focus using Vinten control systems.

Safe Working Environment

In normal operation, remote-controlled equipment can move suddenly and without warning. Since audible warnings are not suitable for use within the studio environment, it is recommended that only trained personnel be allowed to work in the active areas, where remote-controlled heads and pedestals are located. Personnel must be made aware of the potential hazards of working in a robotic environment. To avoid personal injury, personnel should always exercise caution when working in the vicinity of robotic equipment. The forces are sufficient to cause personal injury or injury to others, and therefore caution is essential.

Safe Operating Zone

The safe operating zone for personnel is a minimum of 1 m (3 ft) outside of the footprint of the pan and tilt head. In most installations, the teleprompter (if installed) is mounted onto the head and protrudes the furthest beyond the base of the head. The footprint must take into account the overhang of the teleprompter or other payload equipment as the head moves about the pan axis.

Warning Signs

Warning signs should be displayed prominently in the workplace alerting personnel that robotic equipment is in use and may move suddenly and without warning. If personnel are working on robotic or associated equipment, ensure a warning sign is placed at the controller (control panel) to alert operators that work is being carried out.

Safety Notes for Operators

Operators must familiarise themselves with the working footprint of the robotic head, including all associated equipment (lens, zoom and focus controls, viewfinder, prompter, etc.) to prevent inadvertent collisions or injury to personnel.

If personnel are too close to a head or pedestal that is about to move, the operator should prevent the motion from starting or stop the motion if it has started.

We strongly recommend that the operator verifies visually that the active area is clear of hazards and personnel, both before and during remote operation.

Components and Connections

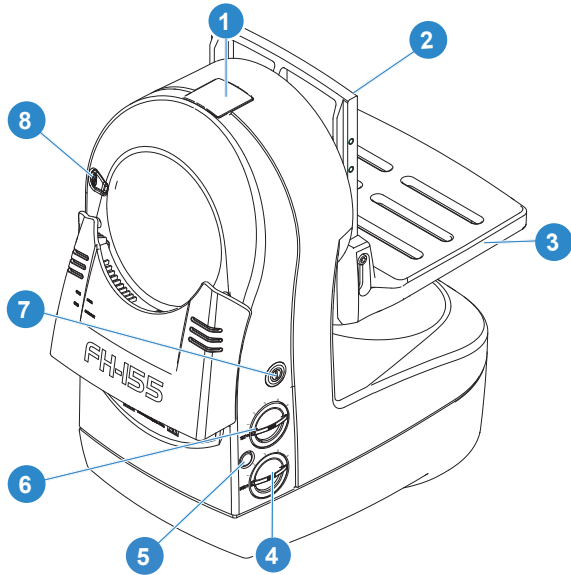

- 1 StarTracker camera fitting location
- Note!** For StarTracker set up information see V4155-4981 User guide
- 2 Camera cradle backplate
- 3 Mounting plate
- 4 Pan drag dial
- 5 Manual pan / tilt control switch (FH-155 Only)
- 6 Tilt drag dial
- 7 Power ON / OFF button
- 8 Tilt lock button
- 9 Genlock / Data indicator lights
- 10 GENLOCK

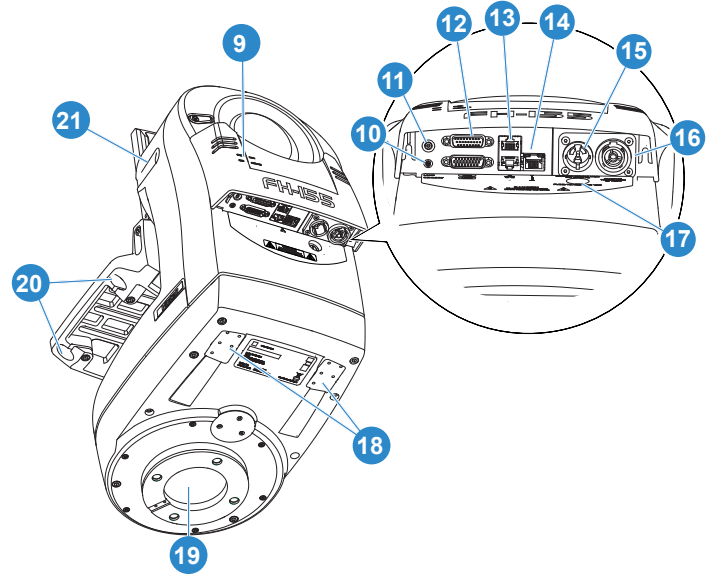

- 11 Lanc
- 12 Serial connectors (Lens, AUX)
- 13 Ethernet port x 2
- 14 Support equipment ethernet port
- 15 Power IN
- 16 Power OUT
- 17 Fuse compartment
- 18 Cable management bracket attachment points
- 19 Base with Quickfix groove, Mitchell key mount
- 20 Rod openings (for pan bar assembly)
- 21 Tilt lock release button

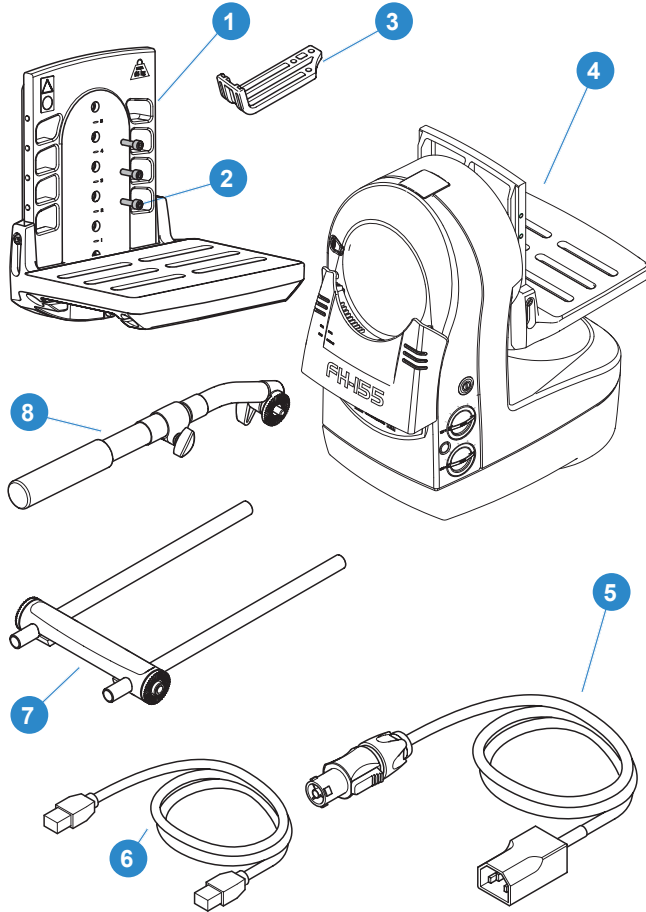

- 1 Camera cradle
..... (Comprising backplate and mounting plate)
 - 2 Centre screws, x3
 - 3 Cable management bracket, large
 - 4 FH-155 / FHR155 pan and tilt head
 - 5 Power cable, 1 m
- CAUTION!** Use only supplied Power Cable: Part No. V4101-5008
- 6 Ethernet cable, Cat5e FTP, 1 m
 - 7 Pan bar assembly (FH-155 only)
..... (Comprising rosette bar and two 400 mm rods)
 - 8 Pan bars, telescopic, black, x2 (FH-155 only)
 - NI Cable ties, black, x5
 - NI M4 countersunk screws (cable bracket), x3
 - NI $\frac{3}{8}$ " BSW x $\frac{3}{4}$ " cap head screws (camera screws), x2
 - NI $\frac{3}{8}$ " head fixing bolts, x4
 - NI Vinten spanner (for head bolts)
 - NI Installation Guide

NI = Not illustrated

Tools Required:

- 5 mm Allen key
- $\frac{5}{16}$ " Allen key
- $\frac{5}{64}$ " Allen key

Flat-blade
screwdriver

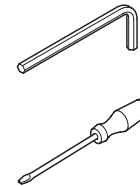

Installation

Mounting Supports and Adaptors

Item No.	Mounting Support or Adaptor	Part No.	Mount
1	Vinten HD Quickfix® Adaptor	3490-3	Vinten HD tripods
2	Mitchell Centre Screw (spider adaptor with Mitchell key)	3724-3	Vinten HD tripods Sachtler OB2000

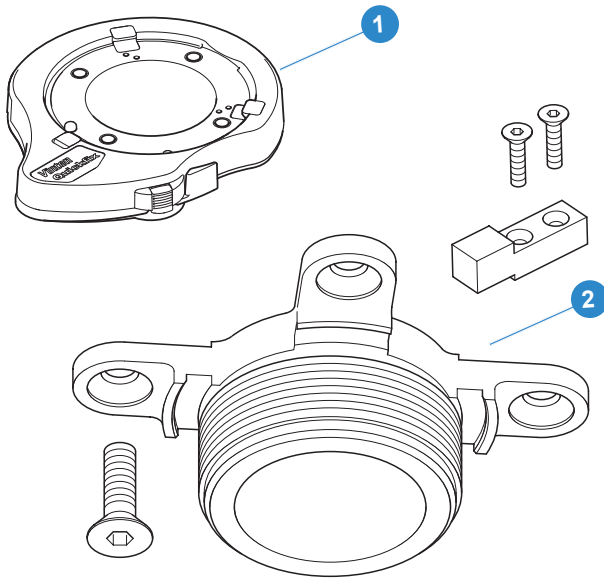

Cable Management Brackets

The FH-155 / FHR-155 is supplied with a large cable management bracket. The bracket can be affixed on the left- or right-hand side and to the front or back of the attachment point. Depending on the camera and head setup, a second large cable management bracket (see below) can also be fitted.

Camera and head connecting cables should be dressed and secured to the bracket(s) to provide strain relief for the connectors.

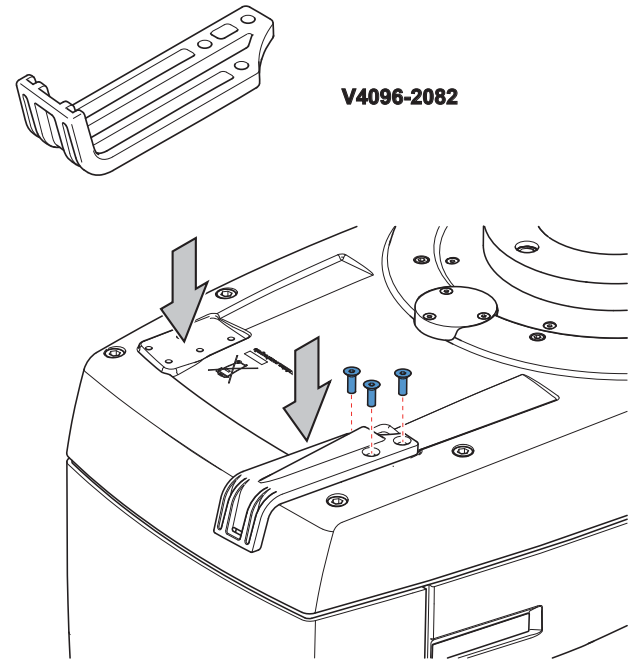

Mounting the Pan Bar Assembly (FH versions only)

For manual operation, mount the pan bar assembly to the camera cradle. Offset pan bars increase the range of movement and improve manoeuvrability of large and unwieldy payloads. The pan bar assembly can be mounted on the left or right-hand side of the camera cradle.

1. Fit the pan bar assembly to the cradle. Insert rods into openings ensuring they cross at least two mounting points

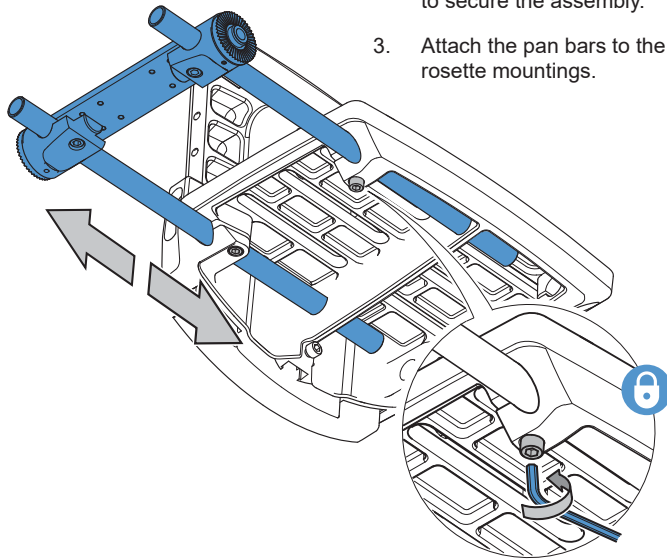

2. Tighten the screws underneath the openings to secure the assembly.
3. Attach the pan bars to the rosette mountings.

HD Tripod Mounting Options

The FH and FHR pan and tilt heads can be mounted onto the following heavy-duty (HD) tripods:

Vinten HDT-1 single-stage tripod

Vinten HDT-2 two-stage tripod

Sachtler OB2000 aluminium tripod



WARNING! Engage the tilt lock before lifting or working on the head.



CAUTION! Do not attempt to manually switch the pan or tilt control switch to AUTO. Robotic mode must be initiated from the control panel.

Mount the head to the HD tripod using either a Mitchell Centre Screw (spider adaptor) and key or a Vinten Quickfix® adaptor. **See Page 8 Mounting Supports and Adaptors**

Installation

Mitchell Centre Screw (3724-3)

Using a $\frac{5}{64}$ " Allen key, attach the Mitchell key to the head base with two 6-32 UNC screws, then use a $\frac{5}{16}$ " Allen key to attach the centre screw or spider adaptor with four $\frac{3}{8}$ " screws. The head can now be mounted directly on the tripod.

The Mitchell key fits into the cut-out in the top of the tripod bowl, preventing the head from twisting.

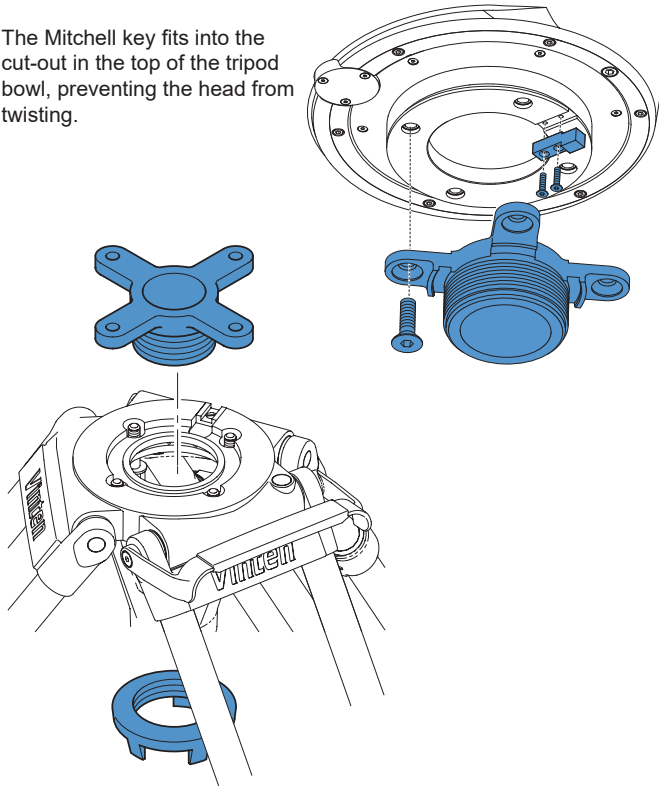

Quickfix Adaptor (V4096-1013)

The base of the FH-155 features a groove that can be used to mount the head using a Quickfix adaptor. Use the adaptor to mount the head directly onto the tripod.

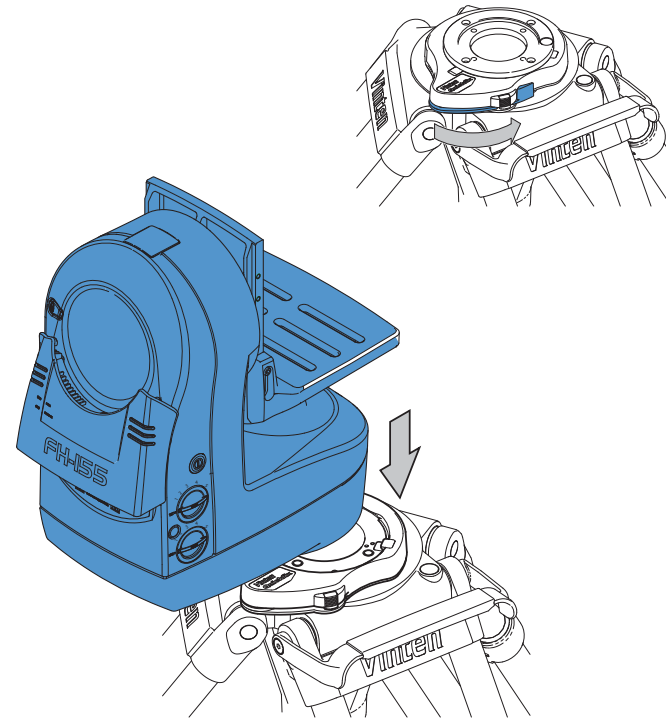

Locking / Unlocking the Camera Cradle



WARNING! The tilt lock **MUST** be engaged before installing or adjusting the camera or payload

The tilt lock mechanism secures the camera cradle in the horizontal position, to provide a stable platform when making adjustments or when lifting the head. The tilt lock is located at the back of the head, on the left-hand side.



The tilt lock can only be operated when the camera cradle is in the horizontal position.

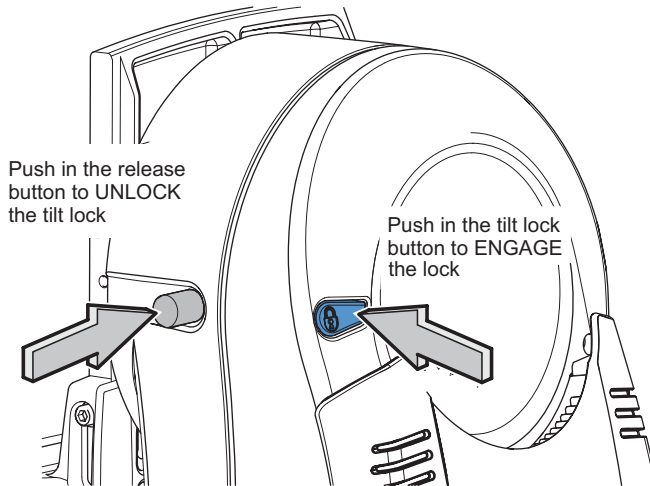

Adjusting the Camera Cradle

The FH-155 is delivered with the camera cradle attached. Note that the cradle is set to the highest setting during transport.

The maximum payload is 70 kg (154 lb).

The camera cradle consists of two parts: a backplate and a mounting plate. The backplate is height adjustable and the two-way height-adjustable mounting plate features rod openings for the pan bar assembly for manual operation of the FH-155 (see page 9 for details).

Refer to page 12 for instructions on how to adjust the cradle.



WARNING! Always support the backplate and / or mounting plate when adjusting them.



WARNING! Heavy – Depending on the weight of the camera and payload combination, adjustments to the cradle must be carried out by 2 or 3 persons.

Installation

1. Adjusting the backplate
(A) Stepped adjustment– Using a 5 mm Allen key, remove the three centre screws and pull the camera cradle off the tilt mounting.

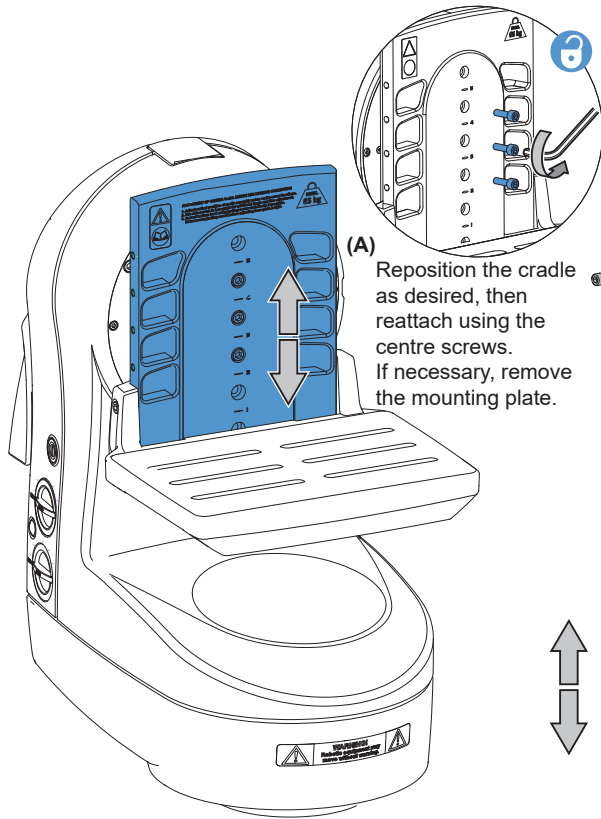

2. Adjusting the mounting plate
(B) Stepped adjustment – Adjust the mounting plate by removing the two side screws and washers and moving the plate to the required attachment point on the side of the backplate. Reattach using the screws and washers.

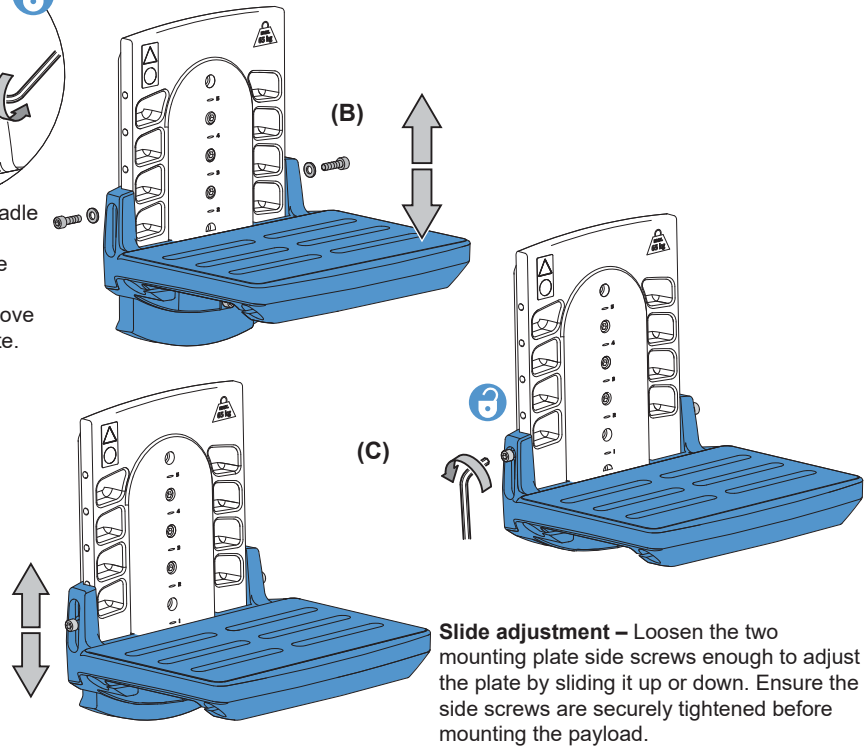

Adjusting the Horizon Level

Using a 5 mm Allen key, tighten the jacking screw underneath the mounting plate to adjust the horizon level of the payload. Loosen the jacking screw before adjusting the height of the mounting plate.

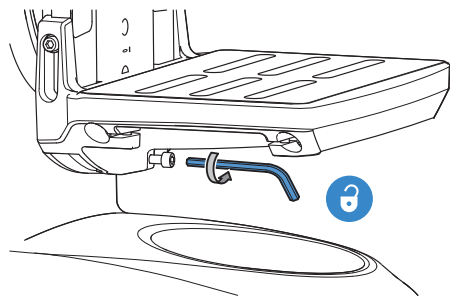

Mounting the Camera

1. Apply the tilt lock. Using a 5 mm Allen key, remove the three centre screws securing the camera cradle and set the camera cradle to its lowest position.
2. Secure the cradle in position. Adjust the jacking screw as required to level the horizon.

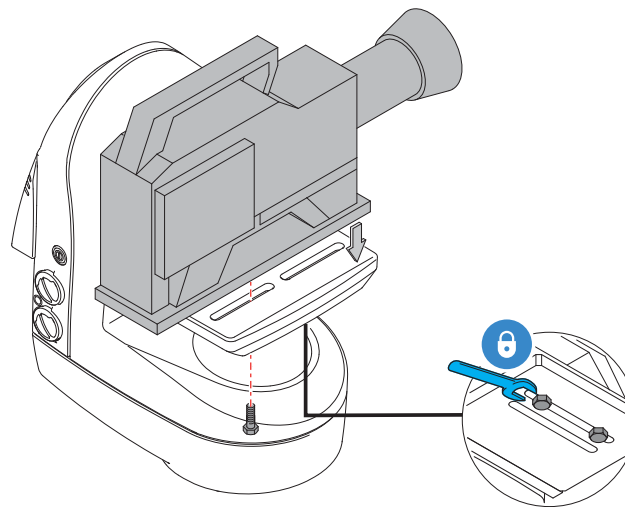
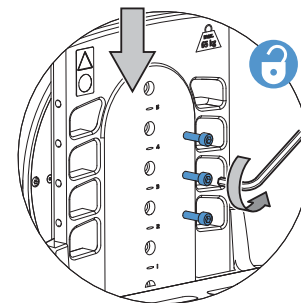

Installation

Balancing the Head

The FH head range is designed to allow the camera and payload to swing about its own Centre of Gravity (C of G), as opposed to balancing with the use of springs or cams. The camera and payload are mounted onto the camera cradle so the resulting C of G aligns with the tilt-axis pivot point, providing true balance.

When the head is correctly balanced, the robotic drives will need a minimum amount of effort to move the head. A correctly balanced head and payload can be set to any tilt position and the head will maintain that position 'hands off'.

Setting the Fore / Aft Balance

Ensure that the head and camera cradle are level before balancing. The camera and payload should be fitted on the cradle, so that the load is balanced. This can be achieved by moving the camera forwards (Fore) or backwards (Aft) on the cradle.



CAUTION! Risk of damage to equipment. Be prepared to prevent the camera and cradle from falling away suddenly.

1. Engage the tilt lock. Loosen the bolts securing the camera to the cradle just enough to be able to slide the camera and payload backwards and forwards.
2. Hold and steady the camera cradle, then disengage the tilt lock. Carefully release the camera cradle and observe how it moves and where it stops.

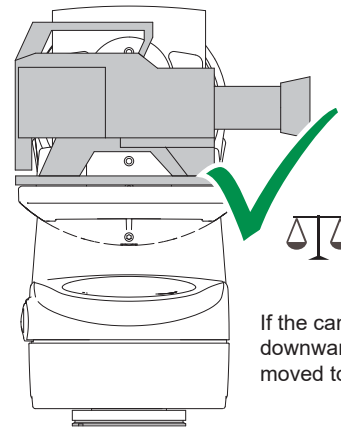

If the camera cradle stops in a horizontal position (camera pointing directly forward), the balance is correct.

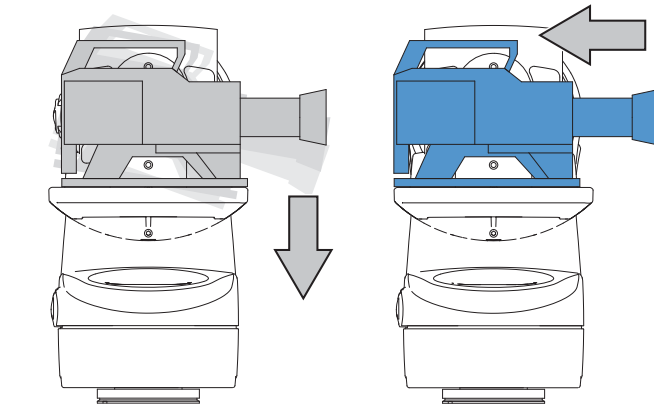

If the camera cradle tilts forward (points downwards), then the camera must be moved towards the rear of the head (aft).

If the camera cradle tilts backwards (points upward), then the camera must be moved towards the front of the head (fore).

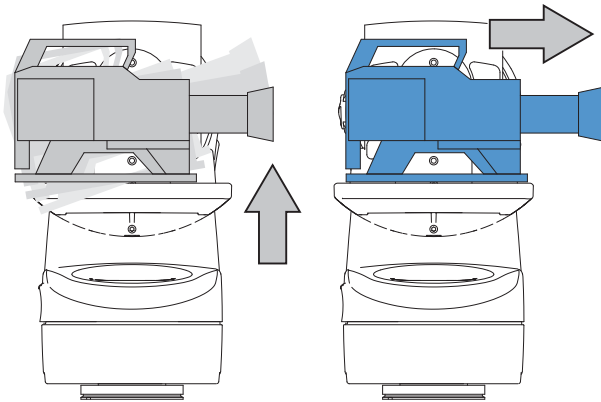

3. Reposition the camera as required on the camera cradle and secure in position. The horizontal balance is correct when the camera cradle comes to rest in a horizontal position.
4. Tighten the bolts securing the camera to the cradle and recheck the horizontal balance. Readjust if necessary.

Adjusting the Centre of Gravity (C of G)



CAUTION! Risk of damage to equipment. Be prepared to prevent the camera and cradle from falling away suddenly.

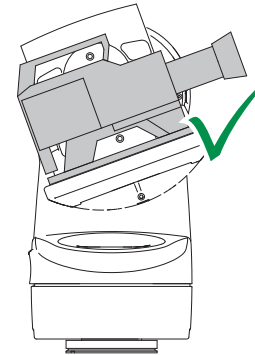

1. Tilt the camera approx. 30° upward and release it.

If the camera stays in the same position when released, the payload is correctly balanced with the C of G on the tilt axis.

If the camera continues to move upwards after releasing the camera cradle, the payload is mounted too high—lower the camera cradle.

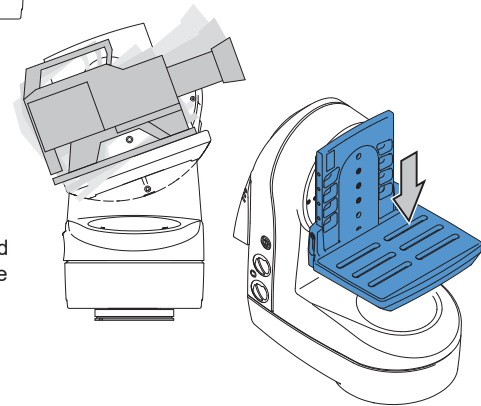

Installation

If the camera moves back towards the horizontal position when released, the payload is mounted too low—raise the camera cradle.

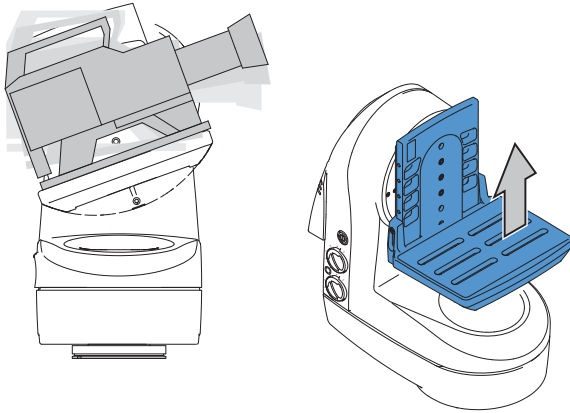

2. Tilt the camera cradle through positive and negative angles of travel, checking that the head remains at the angle of tilt it is set to, unsupported.
If the camera cradle angle falls or rises, repeat the alignment procedure until balance is achieved.
3. After adjusting the C of G height, it may be necessary to check that the fore and aft balance remains satisfactory. Readjust the position of the camera horizontally on the camera cradle as required.
4. After balancing, exercise the head through both axes to confirm that it operates smoothly.

Electrical Connections



CAUTION! Connect the head to the power source using the attached power cable only. Ethernet cables must be rated at Cat5e with screened RJ45 connectors.

1. Connect the lens interface cable to the 26-pin, male Lens interface connector on the FH-155.
2. Connect the power cable and the Ethernet cable.

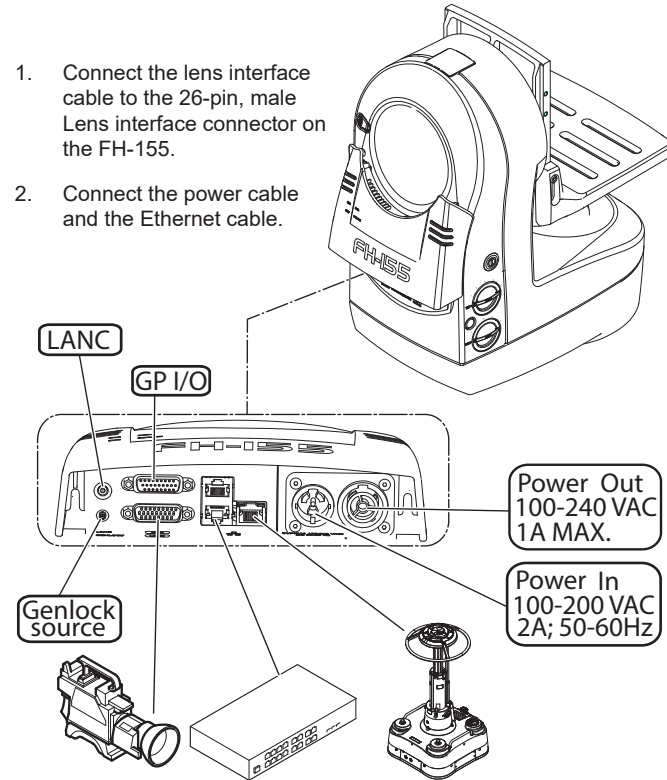

Cable Management

To ensure a safe and tidy installation, all cables connected to the head should be dressed and secured using the cable management bracket supplied. Cables can also be secured to the tripod leg using the cable ties provided.



CAUTION! Leave sufficient slack in the cables between the fixed mounting and the head for free and full range of movement.



CAUTION! Cables must be secured to the cable management bracket when the head is mounted to a tripod.

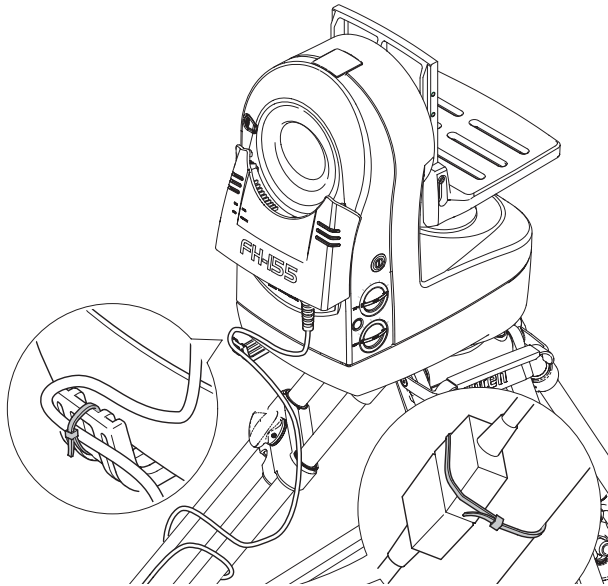

Powering Up



WARNING! Ensure that all personnel are clear from the robotic equipment before powering up.



WARNING! Unexpected movement may occur. Risk of trapped hand / fingers.



CAUTION! Disengage the tilt lock before powering up.

Before powering up the head, ensure that all external cable connections have been secured. To power up, press the power button located on the side of the head. The head will not move when powered up, but zoom and focus servos on the camera will take up their default positions on analogue lenses.

The LEDs located at the rear of the head indicate that data communications (green LED) and a genlock signal (amber LED) is present. If the LEDs do not illuminate on power up, refer to the Troubleshooting section of this manual (see page 20).

Note: FH-155 models only – The head can be switched to MANUAL mode using the control switch on the side of the head; this disengages the robotic drives and engages the drag modules.

Configuring the Head

The head can now be configured for the studio environment using the Advanced Configuration Tool software.

Refer to the V4063-4980 VRC System User Guide, **Advanced Configuration Tool** section.

Operation

Manual Mode (FH models only)

Switching to Manual

The head can be operated in manual mode by a camera operator using the pan bars and adjustable drag modules to control pan and tilt movement.

The head can be switched to manual mode by pressing the manual control button on the side of the head as shown below. This disengages the robotic drives and engages the adjustable servo controlled drag modules.

Note! the drag dials will illuminate when placed in manual mode.

To revert to robotic mode an “enable” command from the parent robotic system must be actioned.

Manual Mode Button

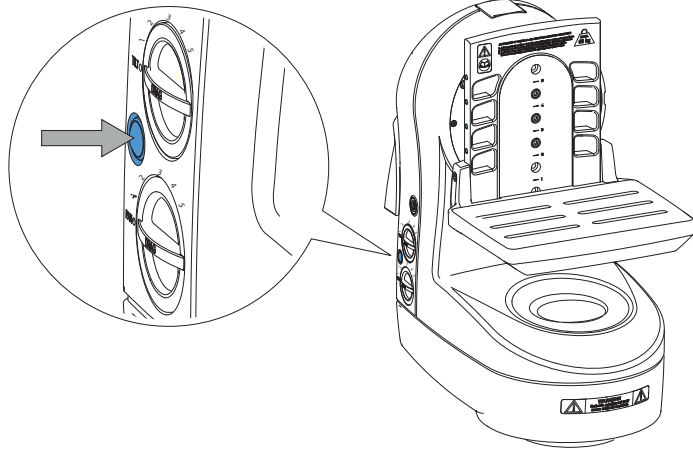

Operating the Drags

Both the pan and tilt axes on the FH models offer drag using the servo motors. The drag is continuously adjustable from low to high in both PAN and TILT by rotating the appropriate dial;

- Clockwise to increase the amount of drag.
- Anti-clockwise to reduce the amount of drag.

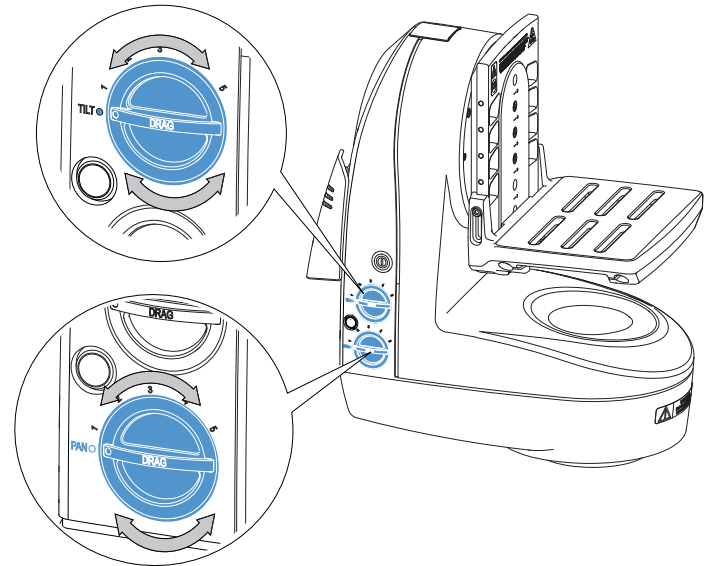

Regular Checks

Routine Use

During use, check the following regularly:

Once a month check the balance of the camera and payload and adjust if necessary.

Check the integrity of bolts and fixings securing the head to the support.

Check the bolts and fixings securing the payload.

No further routine maintenance is required.

Cleaning



WARNING! Risk of electric shock.

Disconnect and isolate the product from the power supply before cleaning.

We encourage regular cleaning of the product. During normal use the only cleaning required should be a regular wipe over with a lint-free dry cloth. External electrical connection ports should only be cleaned with a vacuum cleaner.

Cover the head when not in use. Dirt accumulated during storage or periods of non-use may be removed with a vacuum cleaner.

Changing the Fuse



WARNING! Risk of electric shock.

Disconnect the power cable. Fuses must only be changed by a trained and competent person.



CAUTION! The replacement fuse must be the correct rating: Type T3.15A, 250V AC (Part No. C301-092).

1. Switch OFF and disconnect the power.
2. Using a flat-blade screwdriver or coin, remove the fuse holder.
3. Replace the fuse, then reinstall the fuse holder.

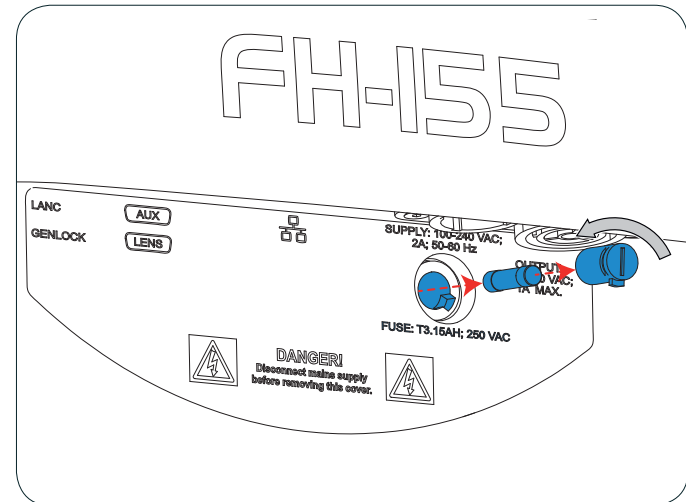

Troubleshooting

Fault	Check	Action
Power supplied, but the camera cradle is not moving	Check that the tilt lock is disengaged	See “ Locking / Unlocking the Camera Cradle ” on page 11
Head not operating	Check the power switch is ON	See “ Powering Up ” on page 17
	Ensure that the power and Ethernet cables are connected and secure	See “ Electrical Connections ” on page 16
	Check mains power supply to the head	Check that power is being supplied from the pedestal, height drive or studio supply
	Check the head fuse and replace as necessary	See “ Changing the Fuse ” on page 19
Camera or payload moving too far on the pan and / or tilt axis	Check the settings of the soft limits	
Intermittent or no communications	Check Ethernet cable Check Ethernet cable is CAT5E FTP	If possible, try using another Ethernet cable. Refer to the V4063-4980 VRC System User Guide, Advanced Configuration Tool section for details on configuring the Ethernet

Specifications

Physical Data	FH-155	FHR-155
Max. Payload	70 kg (155 lb)	70 kg (155 lb)
Cradle	Standard	Standard
Height	490 mm (19.3 in.)	490 mm (19.3 in.)
Length	436 mm (17.2 in.)	436 mm (17.2 in.)
Width	235 mm (9.3 in.)	235 mm (9.3 in.)
Weight	18 kg (39.6 lb) w/o cradle / 22.4 kg (49.3 lb) with cradle	18 kg (39.6 lb) w/o cradle / 22.4 kg (49.3 lb) with cradle
Rated load inertia	7.5 kg m ² (178 lb ft ²)	7.5 kg m ² (178 lb ft ²)
Operating Data		
Temperature range, IP	+5°C to +40°C (+41°F to +104°F) , IP40 non-condensing	+5°C to +40°C (+41°F to +104°F), IP40 non-condensing
Motor noise	41 dBA @ Max speed	41 dBA @ Max speed
Tilt range	±50°(payload dependent)	±50°(payload dependent)
Pan range	359°	359°
Angular velocity (max.)	60°/s	60°/s
Angular acceleration (typical)	60°/s ²	60°/s ²
Angular acceleration (peak)	120°/s ²	120°/s ²
Shot Recall Repeatability	+ - 60 arcseconds (+-0.016°)	+ - 60 arcseconds (+-0.016°)
System Resolution / Accuracy	19 Bit, 0.2°, (21 Bit, >0.01° as option)	19 Bit, 0.2°(21 Bit, >0.01° as option)
Manual control	Yes	No
Drag	Continuous Drag Adjustment, Servo Controlled	No
Lens control	Digital control for most Fujinon, Canon and other Digital lenses, Analogue control for high quality lenses as appropriate, refer to software release and Vitec sales for current supported lenses	Digital control for most Fujinon, Canon and other Digital lenses, Analogue control for high quality lenses as appropriate, refer to software release and Vitec sales for current supported lenses
Network	IP Ethernet, RJ45	IP Ethernet, RJ45
Genlock	Black burst / tri-level, Micro BNC	Black burst / tri-level, Micro BNC
Aux port	26 pin (configurable)	26 pin (configurable)
VR tracking data output	Option, Ethernet UDP or Serial RS232 / 422	Option, Ethernet UDP or Serial RS232 / 422
Electrical Data		
Power consumption	175W	175W
Power input	Autoranging 100–240V AC, 50 / 60 Hz	Autoranging 100–240V AC, 50 / 60 Hz

General Nots

General Purpose Connector

The 26-pin, female GP I/O connector (see page 14) can be configured and enabled in Advanced Configuration Tool. It can be used to connect a Camera Control Unit (CCU) or for powering auxiliary devs. The pin-outs for the connector are given in the table below.

Pin No.	Description	Pin No.	Description
1	Not connected	14	Not connected
2	Aux GND	15	CCU TXD422
3	Aux + 12V	16	CCU TXD232
4	Aux + 12V	17	Not connected
5	Not connected	18	GP I/O 1
6	CCU RXD422	19	GND
7	CCU RXD232	20	Aux GND
8	Not connected	21	Not connected
9	CP I/O 0	22	Not connected
10	GND	23	CCU TXD422
11	Aux GND	24	CCURXD422
12	Aux GND	25	Not connected
13	Aux = 12V	26	GP I/O 2

Compliance

Declaration of Conformity

 Vitec Production Solutions Limited declares that this product has been manufactured in accordance with BS EN ISO 9001:2008 and is in compliance with the essential requirements and other relevant provisions of the Machinery Directive 2006/42/EC.

Product has been tested with a typical network and lens cables, genlock cable <1m as if from camera

A copy of the Declaration of Conformity is available upon request



Waste of Electrical and Electronic Equipment (WEEE) Directive (2012/19/EU)

This symbol marked on the product or its packing indicates that this product must not be disposed of with general household waste. In some countries or European Community regions, separate collection systems have been set up to handle the recycling of electrical and electronic waste products.

By ensuring this product is disposed of correctly you will help prevent potentially negative consequences for the environment and human health. The recycling of materials helps conserve natural resources.

In countries outside the EU:

Dispose of this product at a collection point for the recycling of electrical and electronic equipment according to your local government regulations.

Visit our website for information on how to safely dispose of this product and its packaging.



FH Models

V4155-0001
V4155-0002
V4155-0003
V4155-0004

FHR Models

V4155-0011
V4155-0012
V4155-0013
V4155-0014

FCC Notice

This product complies with the limits for a Class A digital device, pursuant to Part 15 of the FCC Rules. These limits are designed to provide reasonable protection against harmful interference in a residential installation. This equipment generates, uses and can radiate radio frequency energy and, if not installed and used in accordance with the instructions, may cause harmful interference to radio or television reception, which can be determined by turning the equipment off and on, the user is encouraged to try to correct the interference by one or more of the following measures:

- Reorient or relocate the receiving antenna
- Increase separation between the equipment and receiver
- Connect the equipment into an outlet on a circuit different from that to which the receiver is connected
- Consult the dealer or an experienced radio / television technician for assistance.

FCC Warning

Changes or modifications not expressly approved by the party responsible for compliance could void the user's authority to operate the equipment.

FCC Declaration of Conformity

This product complies with Part 15 of the FCC Rules. Operation is subject to the following two conditions:

- (1) This product may not cause harmful interference.
- (2) This product must accept any interference received, including interference that may cause undesired operations.

Pollution Degree 2

This equipment is designed for operation in Pollution Degree 2 environments.





Publication No. V4155-4980/0

Vinten



Vinten
A Vitec Group Brand

www.vinten.com